



केवल कार्यालयीन उपयोग हेतु
(For Official Use Only)

भारत सरकार GOVERNMENT OF INDIA
रेल मंत्रालय MINISTRY OF RAILWAYS



HANDBOOK ON WELDING TECHNIQUES

END USER: Newly Recruited/ Promoted Welders

CAMTECH/ E/ 14-15/ Welding/ 1.0

February, 2015



महाराजपुर, ग्वालियर – 474 005
Maharajpur, GWALIOR - 474 005

HANDBOOK ON WELDING TECHNIQUES

QUALITY POLICY

"To develop safe, modern and cost effective Railway Technology complying with Statutory and Regulatory requirements, through excellence in Research, Designs and Standards and Continual improvements in Quality Management System to cater to growing demand of passenger and freight traffic on the railways".

FOREWORD

Welding is a very common metal joining technology and it is widely used in Railways in various production and maintenance units. Railways recruit ITI qualified welders as well as promote staff to welder category by providing appropriate training.

CAMTECH has prepared this handbook on “Welding Techniques” to provide basic information on the subject. This handbook contains various terms used in electric arc and gas welding.

I hope this handbook will prove to be useful for the newly recruited and promoted welders as well as working welders for updating their knowledge.

CAMTECH, Gwalior
Date : 23rd Feb, 2015

A. R. Tupe
Executive Director

PREFACE

Welding is the most commonly used method of joining and repairing metallic structures permanently. The basic knowledge of weld procedures, weld joints, different techniques is essential to upgrade the workmanship of a welder and to improve productivity in an industry.

CAMTECH has prepared this handbook on “Welding Techniques” by compiling useful information from various sources and books available on the subject. This handbook covers various welding processes, weld types, different electric arc welding processes, safety in electric arc welding, welding electrodes, oxy acetylene gas welding, its equipment, safety in gas welding filler rods, oxy acetylene gas cutting etc. Relevant sketches are given wherever required to make the subject interesting.

It is clarified that this handbook does not supersede any existing instructions/provisions laid down by Railway Board, RDSO, Zonal Railways. This handbook is for guidance only and it is not a statutory document.

I am sincerely thankful to all field personnel who helped us in preparing this handbook.

Technological up-gradation & learning is a continuous process. Please feel free to write to us for any addition/ modification in this handbook. We shall highly appreciate your contribution in this direction.

CAMTECH, Gwalior
Date: 20th Feb, 2015

Peeyoosh Gupta
Director Electrical
e - mail id : direlcamtech@gmail.com

CONTENTS

Item No.	Description	Page No.
	<i>Foreword</i>	<i>iii</i>
	<i>Preface</i>	<i>iv</i>
	<i>Contents</i>	<i>v</i>
	<i>Correction Slip</i>	<i>xi</i>
1.	GENERAL DESCRIPTION	01
1.1	METAL JOINING METHODS	01
1.2	COMPARISON BETWEEN WELDING AND OTHER METAL JOINING METHODS	01
1.3	ADVANTAGES OF WELDING	02
1.4	DIFFERENT METHODS OF WELDING	02
1.4.1	Fusion welding without pressure	02
1.4.2	Pressure welding	02
1.4.3	Non-fusion welding	03
1.5	CLASSIFICATION OF WELDING PROCESSES ACCORDING TO HEAT	03
1.6	CODES FOR WELDING PROCESSES	04
1.7	APPLICATIONS OF VARIOUS WELDING PROCESSES	04
1.8	STATES OF MATTER	05
1.9	COMMON METALS AND ALLOYS	06
1.10	PROPERTIES OF METALS	06
1.10.1	Chemical properties	06
1.10.2	Physical properties	06
1.10.3	Mechanical Properties	07
1.10.4	Effect of welding heat on the properties of metals	08
1.11	EFFECT OF ATMOSPHERIC AIR ON WELDING	08
1.12	TYPES OF WELDS	09
1.12.1	Bead weld	09
1.12.2	Butt weld or groove weld	09
1.12.3	Fillet welds	10
1.12.4	Plug or slot welds	10
2.	ELECTRIC WELDING PROCESSES	11
2.1	ELECTRIC WELDING	11
2.2	TYPES OF ELECTRIC WELDING	11
2.3	ELECTRIC ARC WELDING	12
2.3.1	Metallic arc welding	12
2.3.2	Carbon arc welding	12
2.3.3	Atomic hydrogen arc welding	12
2.3.4	Tungsten inert gas arc welding (TIG)	13
2.3.5	Gas metal arc welding (GMAW) or Metal inert gas arc welding (MIG)	13
2.3.6	Submerged arc welding	14
2.3.7	Electro-slag welding	14
2.3.8	Plasma arc welding	14

Item No.	Description	Page No.
2.4	SHIELDED METAL ARC WELDING (SMAW)	15
2.4.1	Salient Features	15
2.4.2	Advantages	15
2.4.3	Limitations	16
2.4.4	Applications	16
2.5	ARC LENGTH	16
2.5.1	Medium, normal arc	16
2.5.2	Long arc	17
2.5.3	Short arc	17
2.6	SAFETY IN MANUAL METAL ARC WELDING	17
2.6.1	Safety apparels	18
2.6.2	Welding hand screens and helmet	19
2.7	ARC WELDING ACCESSORIES	20
2.7.1	Electrode-holder	20
2.7.2	Earth Clamp	20
2.7.3	Welding cables/ leads	20
2.8	MATERIAL PREPARATION METHOD	21
2.8.1	Cutting	21
2.8.2	Cleaning	21
2.9	OPEN CIRCUIT VOLTAGE AND ARC VOLTAGE	22
2.10	POLARITY IN DC ARC WELDING	22
2.10.1	Importance of polarity in welding	22
2.10.2	Indication of wrong polarity	23
2.11	MILD STEEL WELDING ELECTRODES	23
2.11.1	Electrode sizes	23
2.11.2	Functions of an electrode in shielded metal arc welding (SMAW)	24
2.11.3	Identification of Electrodes	24
2.11.4	Types of electrodes	25
2.12	FLUX COATED ELECTRODES	26
2.12.1	Merits of Flux coated electrodes	26
2.12.2	Coating factor	27
2.12.3	Types of material used in flux coated electrode	27
2.12.4	Electrode coding	27
2.13	WELDING MACHINES (POWER SOURCES)	27
2.13.1	Welding transformer	27
2.13.2	Welding Rectifiers	28
2.13.3	Welding Generator	28
2.13.4	Welding inverters	29
3.	OXY-ACETYLENE GAS WELDING	30
3.1	GAS WELDING	30
3.2	OXY-ACETYLENE WELDING	30
3.2.1	Acetylene	30
3.2.2	Oxygen	30
3.3	OXY-ACETYLENE WELDING EQUIPMENT AND ACCESSORIES	31
3.3.1	Oxygen gas cylinders	31
3.3.2	Dissolved acetylene cylinders	31

Item No.	Description	Page No.
3.3.3	Oxygen pressure regulator	31
3.3.4	Acetylene regulator	31
3.3.5	Rubber hose pipes and connections	32
3.3.6	Hose protectors	32
3.3.7	Blowpipe and nozzle	32
3.4	SAFETY PRECAUTIONS IN HANDLING OXY-ACETYLENE GAS WELDING PLANT	33
3.4.1	General safety precautions	33
3.4.2	Safety concerning gas cylinders	34
3.4.3	Safety of rubber hose-pipes	35
3.5	TROUBLE WITH BLOW PIPE & CYLINDERS	36
3.5.1	Backfire	36
3.5.2	Flashback	36
3.5.3	Cylinder catches fire	37
3.6	TYPES OF OXY-ACETYLENE FLAMES	37
3.6.1	Neutral flame	37
3.6.2	Oxidizing flame	38
3.6.3	Carburizing flame	38
3.6.4	Chemistry of oxy-acetylene flame	38
3.7	FILLER RODS FOR GAS WELDING	39
3.7.1	Filler rod and its necessity	39
3.7.2	Sizes as per IS:1278-1972	40
3.7.3	Types of filler rods	40
3.7.4	Selection of the filler rod	40
3.7.5	Care and maintenance	41
3.7.6	Different filler metals and fluxes for gas welding	42
3.8	WELDING TECHNIQUES OF OXY-ACETYLENE WELDING	44
3.8.1	Leftward Welding Technique	44
3.8.2	Rightward welding technique	46
3.9	WELDING OF LOW CARBON STEEL AND MEDIUM CARBON STEEL	45
3.9.1	Low carbon steels	47
3.9.2	Medium carbon steel	47
3.9.3	High carbon steels	47
4.	OXY-ACETYLENE GAS CUTTING	48
4.1	INTRODUCTION	48
4.2	PRINCIPLE OF GAS CUTTING	48
4.2.1	Cutting Operation	48
4.2.2	Application of Cutting Torch	49
4.3	OXY-ACETYLENE CUTTING EQUIPMENT	49
4.3.1	Cutting Torch	49
4.3.2	Difference between Cutting Torch (Blow Pipe) & welding Blow Pipe	49
4.3.3	Care & Maintenance	50
4.3.4	Problem with Cutting Torch	50

Item No.	Description	Page No.
5.	FAULTS AND DEFECTS IN GAS WELDING	51
5.1	WELD DEFECTS & TYPES	51
5.1.1	External Defects	51
5.1.2	Internal Defects	51
5.2	TYPES OF FAULTS IN GAS WELDING	52
5.3	GAS WELD DEFECTS – POSSIBLE CAUSES AND REMEDIES	55
5.4	ARC WELD DEFECTS – POSSIBLE CAUSES AND REMEDIES	57
	ANNEXURE - I	
	CLASSIFICATION OF ELECTRODE	63
	ANNEXURE – II	
	USAGE & STORAGE OF ELECTRODES	66
	ANNEXURE – III	
	GUNA BAR TECHNIQUE FOR REPAIRING OF CRACKED CAST STEEL BOGIE FRAMES	68
	ANNEXURE – IV	
	WELDING SYMBOLS	70
	REFERENCES	71

CHAPTER 1

GENERAL DESCRIPTION

1.1 METAL JOINING METHODS

The art of joining metals is about 3000 years old. The origin of welding is probably to be traced to the shaping of metals. In industry every worker is working for changing the shape of metals by different methods and machines. Welding is a metal joining method. The following methods are used for joining metals:

(i) Soldering

This joint is made on thin metals using solder as a joining medium. The melting point of solder is less than the metals to be joined. The joint can be opened by heating upto the solder melting temperature (below 400°C).

(ii) Brazing

The joint is similar to soldering but has more strength. The joining medium used is brass, which has a higher melting temperature than solder. The joint can also be opened by heating upto the melting point of brass (850-950°C).

(iii) Welding

A metal joining method in which the joining edges are heated and fused together with or without filler metal to form a permanent (homogeneous) bond is known as welding.

Or in other words, “Welding is a process of joining two or more pieces of the same or dissimilar materials to achieve complete coalescence. This is the only method of developing monolithic structures and it is often accomplished by the use of heat and/or pressure.

1.2 COMPARISON BETWEEN WELDING AND OTHER METAL JOINING METHODS

Joining methods like riveting, assembling with bolt, seaming, soldering and brazing all result in temporary joints. Welding is the only method to join metals permanently.

The temporary joints can be separated if:

- the head of the rivet is cut
- nut of the bolt is unscrewed
- hook of the seam is opened
- more heat is given than that required for soldering and brazing.

Welded joints cannot be separated like soldering and brazing because it is made homogeneous by heating and fusing the joining edges together.

1.3 ADVANTAGES OF WELDING

Welding is superior to other metal joining methods because it:

- is a permanent pressure tight joint
- occupies less space
- gives more economy of material
- has less weight
- withstands high temperature and pressure equal to joined material
- can be done quickly
- gives no colour change to joints.

It is the strongest joint and any type of metal of any thickness can be joined.

1.4 DIFFERENT METHODS OF WELDING

Welding is a method of joining metals permanently. It is an ancient method, about 1500 years old. The method used in ancient days was forge or blacksmith welding.

One of the methods of classifying welded joints is the method used to effect the joint between metal pieces. Accordingly the methods are:

- fusion method without pressure/ with pressure
- non-fusion method

1.4.1 Fusion Welding Without Pressure

A method of welding in which similar and dissimilar metals are joined together by melting and fusion their joining edges with or without the addition of filler metal but without the application of any kind of pressure is known as fusion welding without pressure.

The joint made is permanent. The common heating sources are:

- arc welding
- gas welding
- chemical reaction (thermit welding)



1.4.2 Pressure Welding

This is a method of welding in which similar metals are joined together by heating them to plastic or partially molten state and then joined by pressing or hammering without the use of filler metal. This is fusion method of joining with pressure.

Heat source may be blacksmith forge (forge welding) or electric resistance (resistance welding) or friction.

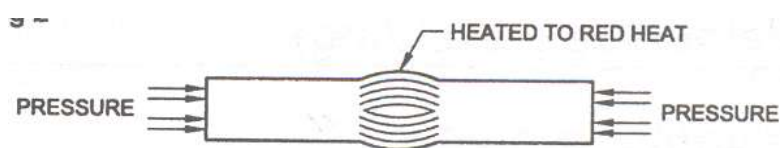

1.4.3 Non-Fusion Welding

This is a method in which similar or dissimilar metals are joined together without melting the edges of the base metal by using a low melting point filler rod but without the application of pressure.

1.5 CLASSIFICATION OF WELDING PROCESSES ACCORDING TO HEAT SOURCE

According to the sources of heat, welding processes can be broadly classified as:

- Electric welding processes (heat source is electricity)
- Gas welding processes (heat source is gas flame)
- Other welding processes (heat source is neither electricity nor gas flame)

❖ **Electric welding processes can be classified as:**

- Electric arc welding
- Electric resistance welding
- Laser welding
- Electron beam welding
- Induction welding

❖ **Electric arc welding can be further classified as:**

- Metallic arc welding
- Carbon arc welding
- Atomic hydrogen arc welding
- Inert gas arc welding/ TIG welding
- CO₂ gas arc welding
- Flux cored arc welding
- Submerged arc welding
- Electro-slag welding
- Plasma arc welding

❖ **Electric resistance welding can be further classified as:**

- Spot welding
- Seam welding
- Butt welding
- Flash butt welding
- Projection welding

❖ **Gas welding processes can be classified as:**

- Oxy-acetylene gas welding
- Oxy-hydrogen gas welding
- Oxy-coal gas welding
- Oxy-liquefied petroleum gas welding
- Air acetylene gas welding

❖ **The other welding processes are:**

- Thermit welding
- Forge welding
- Friction welding
- Ultrasonic welding
- Explosive welding
- Cold pressure welding
- Plastic welding

1.6 CODES FOR WELDING PROCESSES

Code	Welding process	Code	Welding process
AAW	Air acetylene	AHW	Atomic hydrogen
BMAW	Bare metal arc	CAW	Carbon arc
EBW	Electron beam	EGW	Electro gas
ESW	Electro slag	FCAW	Flux cored arc
FW	Flash	FLOW	FLOW
GCAW	Gas carbon arc	GMAW	Gas metal arc
GTAW	Gas tungsten arc	IW	Induction
LBW	Laser beam	OAW	Oxy-acetylene
OHW	Oxy-hydrogen	PAW	Plasma arc
PGW	Pressure gas	RPW	Resistance projection
RSEW	Resistance seam	RSW	Resistance spot
SAW	Submerged arc	SMAW	Shielded metal arc
SCAW	Shielded carbon arc	SW	Stud arc
TW	Thermit	UW	Ultrasonic

1.7 APPLICATIONS OF VARIOUS WELDING PROCESSES

- **Forge welding** is used in olden days for joining metals as a lap and butt joint.
- **Metallic arc welding** is used for welding all ferrous and non-ferrous metals using consumable stick electrodes.
- **Carbon arc welding** is used for welding all ferrous and non-ferrous metals using electrodes and separate filler metal. But this is a slow welding process and so not use now-a-days.
- **Submerged arc welding** is used for welding ferrous metals, thicker plates and for more production.
- **CO₂ welding (gas metal arc welding)** is used for welding ferrous metals using continuously fed filler wire and shielding the weld metal and the arc by carbon-dioxide gas.
- **TIG welding (inert gas arc welding)** is used for welding ferrous metals, stainless steel, aluminium and thin sheet metal welding.
- **Atomic hydrogen welding** is used for welding all ferrous and non-ferrous metals and the arc has a higher temperature than other arc welding processes.

- **Electro-slag welding** is used for welding very thick steel plates in one pass using the resistance property of the flux material.
- **Plasma arc welding:** The arc has a very deep penetrating ability into the metals welded and also the fusion is taking place in a very narrow zone of the joint.
- **Spot welding** is used for welding thin sheet metal as a lap joint in small spots by using the resistance property of the metals being welded.
- **Seam welding** is used for welding thin sheets similar to spot welding. But adjacent weld spots will be overlapping each other to get a continuous weld seam.
- **Projection welding** is used to weld two plates one over the other on their surfaces instead of the edges by making projection on one plate and pressing it over the other flat surface. Each projection acts as a spot weld during welding.
- **Butt welding** is used to join the ends of two heavy section rods/ blocks together to lengthen it using the resistance property of the rods under contact.
- **Flash butt welding** is used to join heavy sections of rods/ blocks similar to butt welding except that arc flashes are produced at the joining ends to melt them before applying heavy pressure to join them.
- **Oxy-acetylene welding** is used to join different ferrous and non-ferrous metals, generally of 3 mm thickness and below.
- **Oxy-other fuel gases welding:** Fuel gases like hydrogen, coal gas, liquefied petroleum gas (LPG) are used along with oxygen to get a flame and melt the base metal and filler rod. Since the temperatures of these flames are lower than the oxy-acetylene flame, these welding are used to weld metals where less heat input is required.
- **Air-acetylene gas welding** is used for solder, heating the job etc.
- **Induction welding** is used to weld parts that are heated by electrical induction coils like brazing of tool tips to the shank, joining flat rings etc.
- **Thermit welding** is used for joining thick, heavy irregularly shaped rods, like rails, etc using chemical heating process.
- **Friction welding** is used to join the ends of large diameter shafts etc. by generating the required heat using the friction between their ends in contact with each other by rotating one rod against the other rod.

1.8 STATES OF MATTER

There are three states of matter exist as:

- Solid
- Liquid
- Gas

In welding, a metal to be welded will be in the solid state before welding. During welding the solid state changes to liquid state and at the end of the welding operation, the liquid state again changes to solid state.

1.9 COMMON METALS AND ALLOYS

Metals may be ferrous, non-ferrous metals and alloys.

Ferrous metals are those which have iron as their base. They include iron and its alloys such as steel, cast iron and alloy steels such as stainless steel etc.

Non-ferrous metals do not contain iron as base. They include copper, aluminium, zinc, tin etc and non-ferrous alloys.

Alloys

If two or more metals are chemically combined they form an alloy e.g. iron, chromium nickel and carbon form an alloy called chromium nickel steel (stainless), manganese, iron and carbon form an alloy called manganese steel, copper and zinc form an alloy called brass, copper and tin form an alloy called bronze, lead and tin form an alloy called soft solder.

1.10 PROPERTIES OF METALS

Properties of metals can be classified mainly into:

- Chemical properties
- Physical properties
- Mechanical properties

1.10.1 Chemical Properties

Chemical properties are those which involve chemical effect such as:

- Corrosion
- Oxidation
- Reduction

Corrosion will spoil the metal surface due to the effect of various elements in the atmosphere and water.

Oxidation is the formation of metal oxides which occur when oxygen combines with metals.

Reduction refers to the removal of oxygen from the surrounding molten puddle to reduce the effect of atmospheric contamination.

1.10.2 Physical Properties

Physical properties are those, which affect metals when they are subjected to heat generated by welding such as:

- melting point
- thermal conductivity
- thermal expansion
- grain growth

Melting point

Melting point is the degree of temperature, when a solid metal changes into liquid. Melting points of some metals are given below:

1.	Mild steel	1500 to 1530°C
2.	Cast iron	1150°C
3.	Copper	1083°C
4.	Aluminium	659°C
5.	Brass and bronze	850°C-950°C
6.	Zinc	419°C
7.	Tin	232°C
8.	Lead	327°C
9.	Nickel	1452°C
10	Soft solder (50% lead, 50% tin)	216°C

Thermal conductivity

Thermal conductivity is the rate at which a metal conducts heat to the adjacent area of the heated job. Copper conducts heat faster than aluminium. Aluminium conducts heat faster than iron.

Thermal expansion

Whenever metals are heated there will be increase in its dimensions due to their thermal expansion property. Depending on the nature of metal, different metals will have different thermal expansion.

Grain structure

Like salt or sugar, the metal is also a crystalline substance. In metals the crystals are called grains. Grains are composed of atoms. Atomic structure determines the grain structure just as the arrangement of bricks determines the shape of the building. During welding (due to heating effect) the grain size increases resulting in the loss of strength.

1.10.3 Mechanical Properties

Mechanical properties are those which determine the behavior of metals under applied load such as:

- Tensile strength
- Ductility
- Hardness
- Toughness
- Brittleness

Tensile strength is the property of the metal which resists forces acting to pull it apart.

Ductility is the ability of the metal to stretch, bend or twist without breaking or cracking or to draw into fine wires.

Hardness is the ability of the metal to withstand abrasions, cutting action by a tool. Usually any hard metal will resist the compressive forces. Normally a hard metal will also be brittle.

Toughness is the ability of a metal to withstand sudden force without breaking.

Brittleness is the property of the metal which is opposite of ductility and is applied to a metal which cracks suddenly if placed pressure or load to bend or twist.

1.10.4 Effect of Welding Heat on the Properties of Metals

During welding the properties of the weld metal may be affected.

- Important alloying elements may be destroyed.
- Brittle, hard or cracked welds may be produced.
- There may be reduction in the corrosion resistance properties of the welds.
- Main properties of the base metal and weld metal will get affected

1.11 EFFECT OF ATMOSPHERIC AIR ON WELDING

The atmospheric air is a gaseous mixture of mainly nitrogen and oxygen, with some other gases like hydrogen, etc. in small percentages.

Since the atmospheric air contains 21% of oxygen, whenever a red hot or molten iron comes in contact with atmospheric air the metal gets oxidized.

Oxygen contamination i.e. oxidation will reduce the mechanical properties of the weld metal. In other words the tensile strength, toughness and ductility of the weld decrease with increased oxygen contamination.

The nitrogen injected into the weld pool, during the solidification of the weld metal, forms bubbles and results in the formation of gas porosity in the weld metal. This reduces the strength of the joint. In addition, the atmospheric nitrogen will combine with the molten metal and the weld hardened due to the formation of iron nitride. For the above reason the weld metal must be protected from the atmospheric contamination either by using suitable flux or with insert gas shielding.

If there is more moisture (water) present in the atmospheric air (particularly during rainy and winter season) the iron gets oxidized (i.e. rusted) due to long storage.

The formation of oxides and nitrides due to the contact of atmospheric air with the molten metal is also called as **atmospheric contamination**.

Effects of oxidation

During the welding process the combination of a metal with oxygen (oxide) may cause the following effects:

- i. Produce blow holes in the weld beads.
- ii. Produce oxides which are having a higher melting point than that of the surrounding metals. This will form solid particles (oxide inclusions) in the weld metal in the case of non-ferrous metals.

- iii. Produce oxides which will dissolve in the molten metal and make the metal brittle and weak.
- iv. The oxides of wrought iron and steel melt at a temperature lower than that of the parent metal, and being light, float to the surface as a scale.

If care is taken in the welding process, the oxides will not cause trouble during welding.

There are some effects of oxidation on the filler rods, powder type fluxes used in gas welding and on the electrode core wire and the flux coated on them. If proper care is not taken to protect the filler rods, fluxes and M.S. coated electrodes to store them properly, they will get rusted. The fluxes will pick up moisture from the wet atmosphere and will become useless/ deteriorated.

However, the oxidation of metals has also certain useful effects i.e. a stream of pure oxygen if applied (used) on a red hot mild steel plate through a nozzle, the plate will get cut into 2 pieces. Hence the principle of **oxidation is effectively used in Gas cutting** and gouging of mild steel.

1.12 TYPES OF WELDS

To get different welding joints the following types of weld are used:

- Bead weld
- Groove or butt weld
- Fillet weld
- Plug or slot weld

1.12.1 Bead Weld

Bead weld is a type of weld composed of one or more stringer or weave beads deposited on an unbroken surface to obtain the desired properties and dimensions.

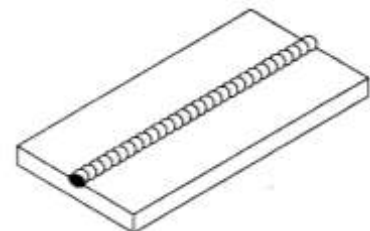

1.12.2 Butt Weld or Groove Weld

Butt weld or groove weld is a weld made in the groove between two members to be joined as butt joint. Groove welds are also done on T fillet joints if the plate thickness is more than 12mm.

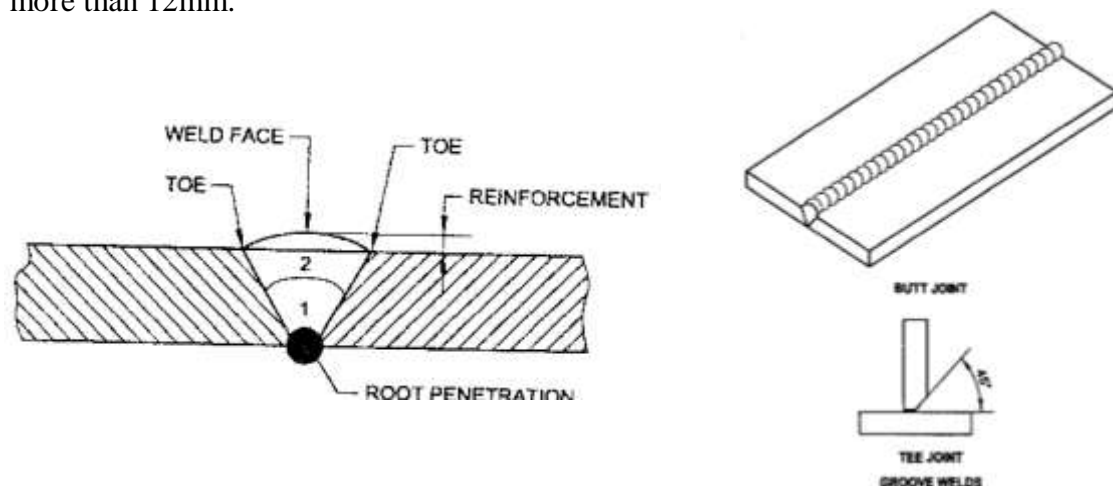

1.12.3 Fillet Welds

Fillet weld is a weld, having a triangular cross-section, joining two surfaces at right angle to each other such as:

- Lap joint
- Tee joint
- Corner joint

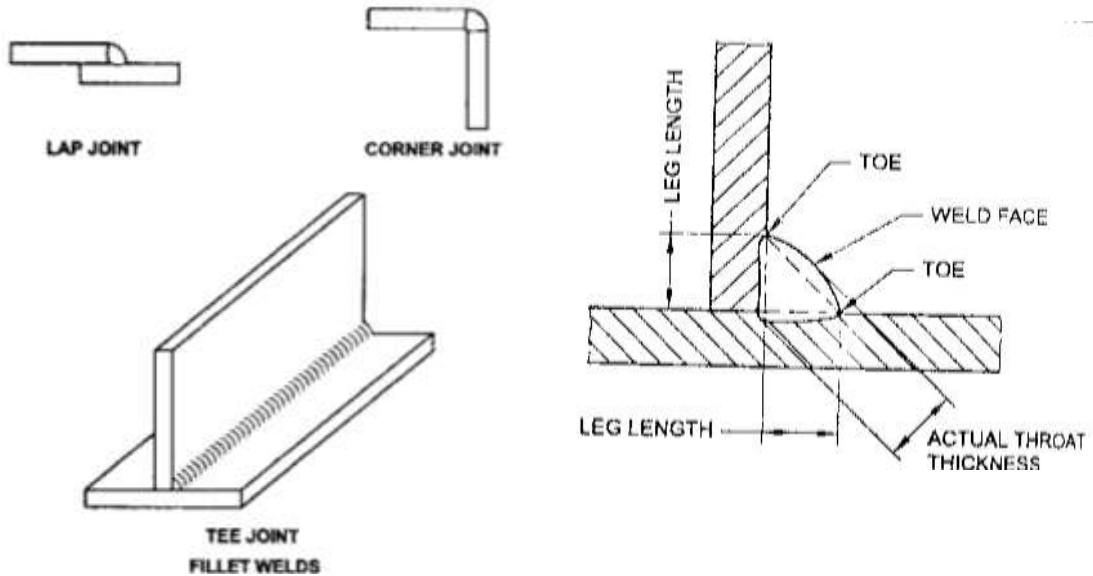

1.12.4 Plug or Slot Welds

Plug or slot welds are welds used to join two over-lapping pieces of metal by welding through circular holes or slots. These welds are often used in the place of rivets.

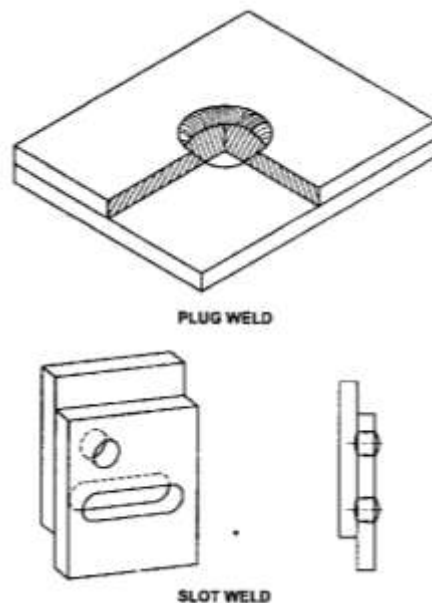

CHAPTER 2

ELECTRIC WELDING PROCESSES

2.1 ELECTRIC WELDING

This is a process of welding in which the heat energy is obtained from electricity.

Formula for converting electrical energy to heat energy

$$H = I^2RT$$

Where

- H is the amount of heat produced in 'joules'.
- I is the amount of current passing in amps.
- R is the resistance of medium in ohms.
- T is the time during which the current flows.

This is useful only in the resistance welding process.

2.2 TYPES OF ELECTRIC WELDING

There are mainly two types of electric welding processes classified as follows:

(i) Electric arc welding

It is a fusion-welding (non-pressure) process in which the welding heat is obtained from an arc, formed between an electrode and the welding job connected to a suitable welding machine.

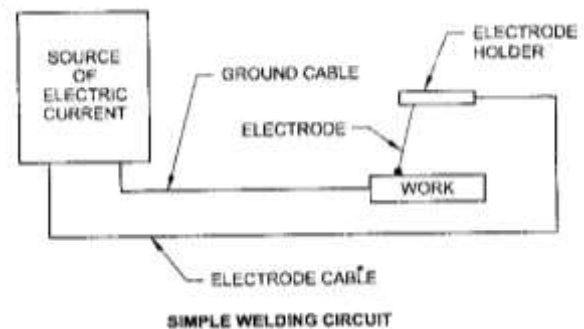

(ii) Electric resistance welding

It is a pressure-welding process in which the heat is obtained by passing a heavy momentary electric current through the inherent electric resistance of the joint to be welded. When the joint reaches a plastic state, sufficient pressure is applied to produce fusion and get a homogeneous weld.

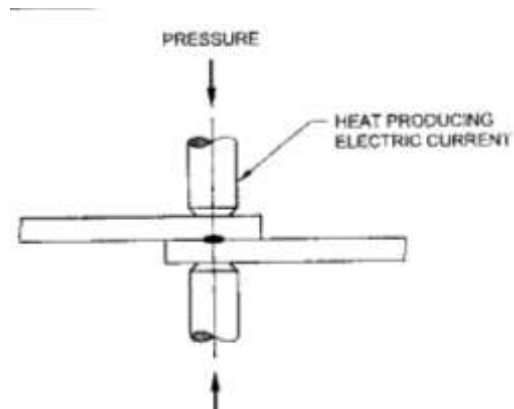

2.3 ELECTRIC ARC WELDING

Electric arc is formed when both the terminals of an electric circuit are brought together and then separated by a small gap. When high current passes through an air gap from one conductor to another, it produces very intense and concentrated heat in the form of a spark. The temperature of this spark (or arc) is app. 3600°C , which can melt and fuse the metal very quickly to produce a homogeneous weld. The types of electric arc welding are as follow.

2.3.1 Metallic Arc Welding

This is an arc welding process in which the welding heat is obtained from an arc, formed between a metallic (consumable) electrode and welding job. The metal electrode melts itself and acts as a filler metal.

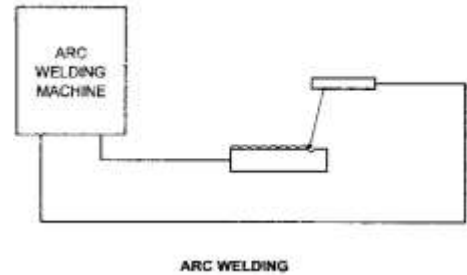

2.3.2 Carbon Arc Welding

Here the arc is formed between a carbon electrode (non-consumable) and the welding job. A separate filler rod is used since the carbon electrode is a non-metal and will not melt.

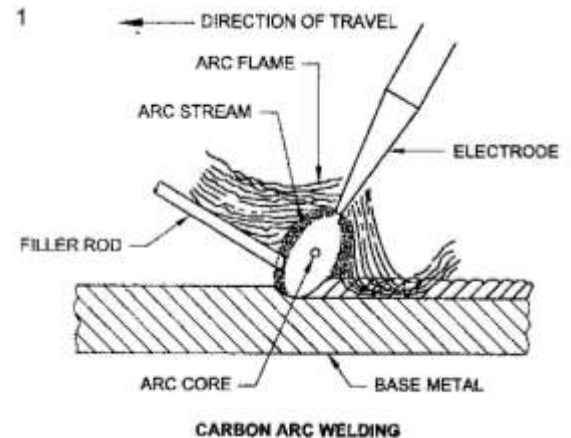

2.3.3 Atomic Hydrogen Arc Welding

In this process the arc is formed between two tungsten electrodes in an atmosphere of hydrogen gas. The welding job remains out of the welding circuit and a separate filler rod is used to add the filler metal.

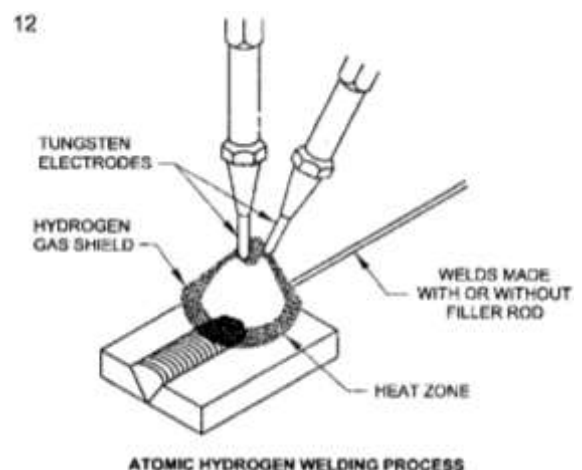

2.3.4 Tungsten Inert Gas Arc Welding (TIG)

In this process the arc is formed between the tungsten electrodes (non-consumable) and the welding job in an atmosphere of an inert gas (argon or helium). A separate filler rod is used to add the filler metal. This process is also called gas tungsten arc welding (GTAW) process.

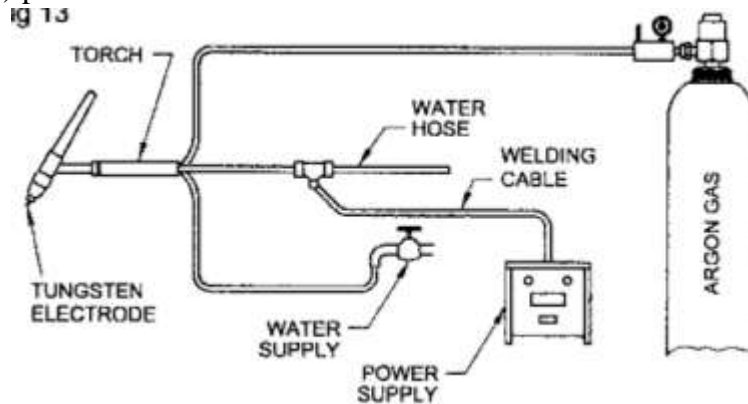

2.3.5 Gas Metal Arc Welding (GMAW) or Metal Inert Gas Arc Welding (MIG)

In this process the arc is formed between a continuous, automatically fed, metallic consumable electrode and welding job in an atmosphere of inert gas, and hence this is called metal inert gas arc welding (MIG) process.

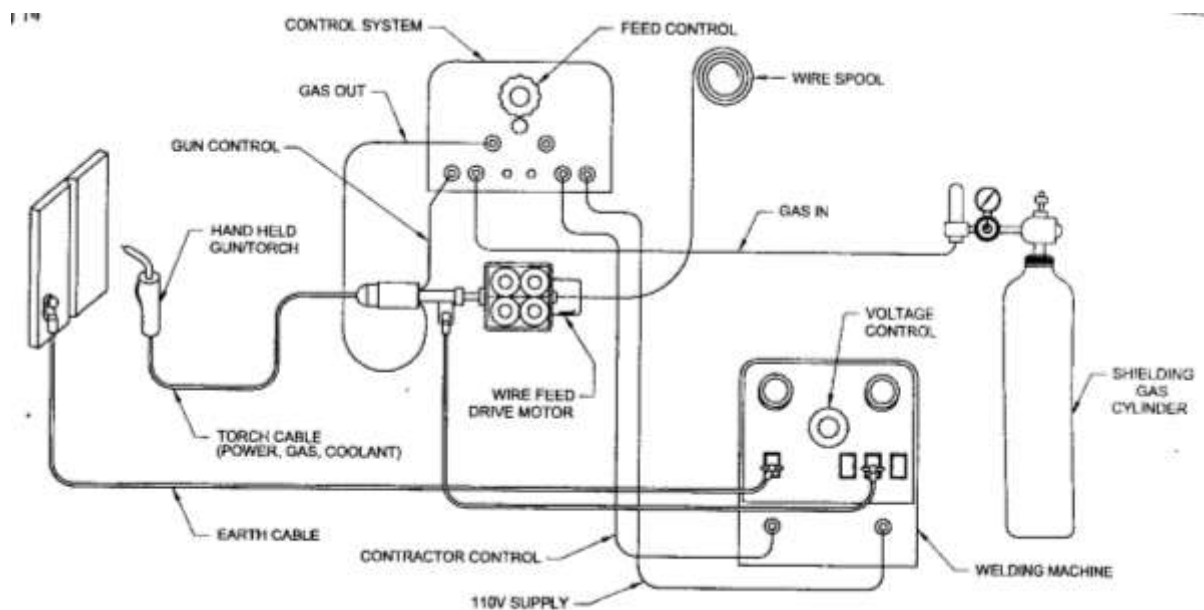

When the inert gas is replaced by **carbon dioxide** then it is called **CO₂ arc welding** or **metal active gas (MAG) arc welding**.

The common name for this process is **gas metal arc welding (GMAW)**.

2.3.6 Submerged Arc Welding

In this process the arc is formed between a continuous, automatically fed, metallic consumable electrode and the welding job under a heap of powdered/ granulated flux. The arc is totally submerged in the flux (invisible).

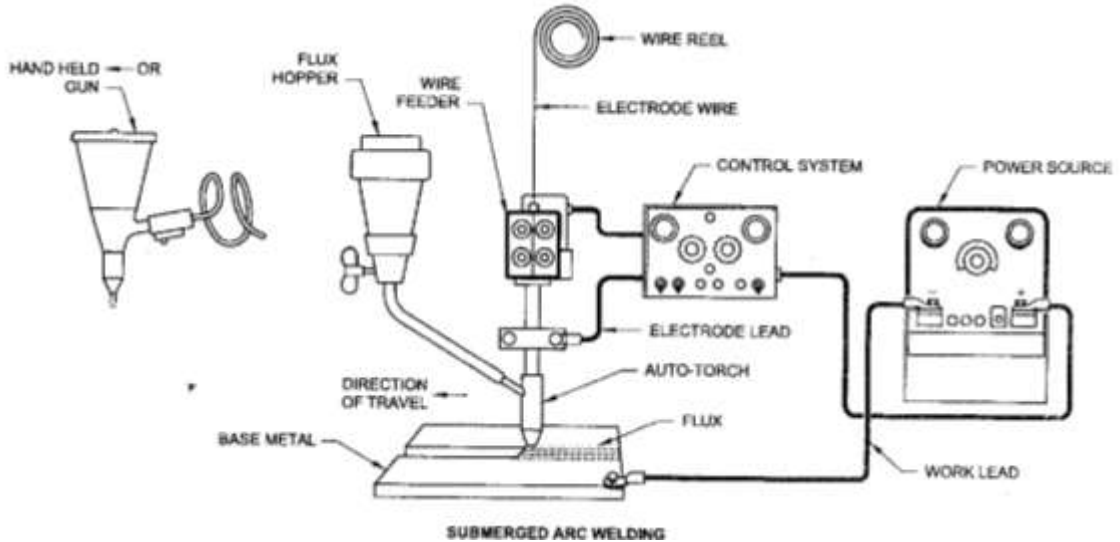

2.3.7 Electro-Slag Welding

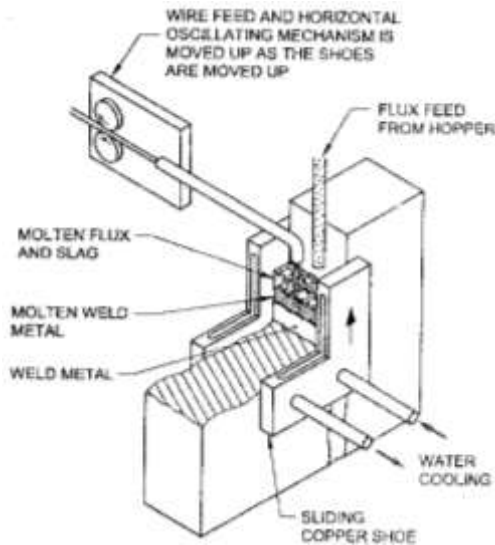

The arc is formed between a continuous, automatically fed, metallic consumable electrode and the welding job under a thick pool of molten flux (slag). This automatic process requires special equipment and is used only in vertical position for the welding of heavy thick plates.

2.3.8 Plasma Arc Welding

In this process the arc is formed between a tungsten electrode and the welding job in an atmosphere of plasma-forming gas—nitrogen, hydrogen and argon. A separate filler rod is used to add the filler metal in the joint, if necessary. But normally no filler rod is used.

The process is similar to TIG welding. Plasma cutting is used to cut non-ferrous metals and alloys successfully and quickly.

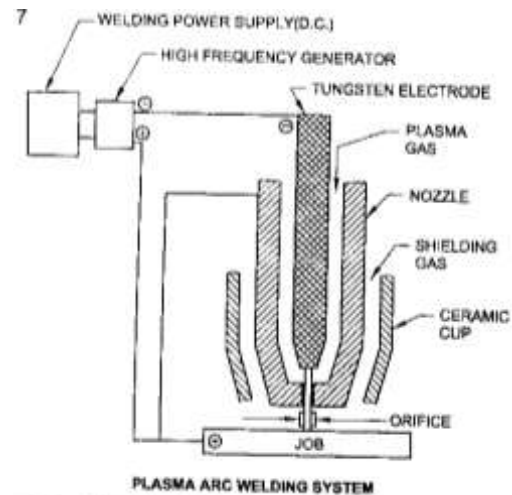

2.4 SHIELDED METAL ARC WELDING (SMAW)

2.4.1 Salient Features

- It is an arc welding process in which the heat required for the welding comes from an electric arc.
- The electric arc develops when electricity jumps across an air gap (ionization of air) between the end of the metallic electrode and the welding job surface.
- The metallic electrode is generally coated with a flux which is consumable.
- The arc created due to the ionization of air between the electrode tip and the base metal generates an intense arc heat having a temperature between 3600°C-4000°C.
- The welding current is provided by an AC or DC machine.
- The intense heat of the arc melts a small portion (molten pool) on the job directly under the arc and at the end of the electrode instantaneously.
- The melted electrode fuses into the molten pool of the welding job and produces a homogeneous weld on cooling.
- The flux coating on the electrode also melts and provides a gaseous shield around the arc which protects the molten metal from atmospheric contamination. Hence this is called **shielded metal arc welding (SMAW)**.
- The welding speed and feed of the electrode is controlled manually by the welder himself. So it is also called **manual metal arc welding (MMAW)**.
- When the weld metal solidifies, the slag (of flux coating) gets deposited on its surface as it is lighter than the metal and the weld metal is allowed to cool gradually and slowly.

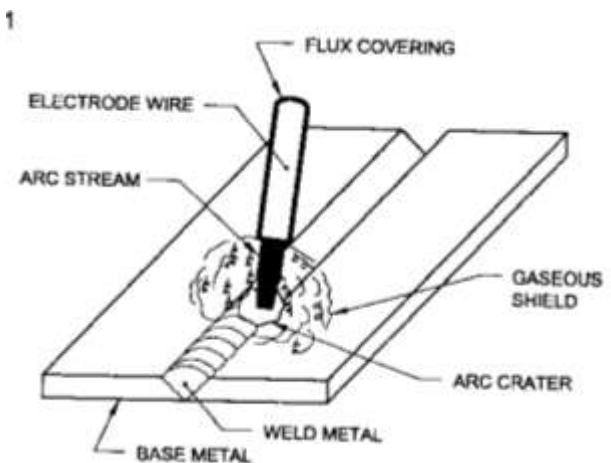

2.4.2 Advantages

The process is widely used because of the following advantages:

- All kinds of light and heavy gauge metals can be welded.
- It can be used for fabrication, construction as well as maintenance works.
- All types of metals (ferrous, non-ferrous and alloys) can be welded.
- It permits a skilled operator to perform the welding operation quickly and easily.
- It is more suitable for short length welds.
- It is less expensive than the other processes.
- It is less sensitive to weld than the other arc welding processes.
- It is portable.

2.4.3 Limitations

- Less metal is deposited per hour and so can not be used for heavy fabrication welding.
- Requires more welders to be employed.
- Controlling the distortion is difficult.
- Continuous and automatic welding is not possible due to the specific length of the electrode.
- More strain to the welder.

2.4.4 Applications

- It is used for welding thin gauge as well as thick gauge metals in small and medium scale industries.
- Used in welding bridges, bus bodies, domestic items like grills for gate, windows, doors, chairs and tables.
- Used in welding roof structures for workshops, broken and cracked castings, water and oil tanks.
- Whenever welding is done in outdoor work, this process is very useful as a diesel generator welding set can be used.
- This process is used for reconditioning, hard facing, rectifying broken parts and repair welding.

2.5 ARC LENGTH

It is the straight distance between the electrode tip and the job surface when the arc is formed. There are three types of arc lengths:

- Medium or normal
- Long
- Short

2.5.1 Medium, Normal Arc

The correct arc length or normal arc length is approximately equal to the diameter of the core wire of the electrode. This is a stable arc producing steady sharp cracking sound and causing:

- Even burning of the electrode
- Reduction in spatters
- Correct fusion and penetration
- Correct metal deposition

It is used to weld mild steel using a medium coated electrode. It can be used for the final covering run to avoid undercut and excessive convex fillet/reinforcement.

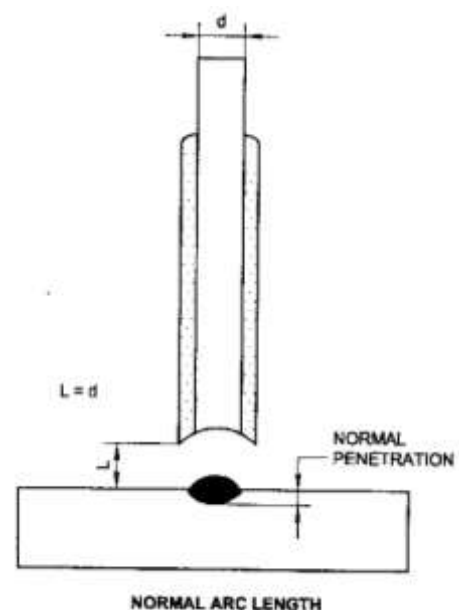

2.5.2 Long Arc

If the distance between the tip of the electrode and the base metal is more than the diameter of the core wire it is called a long arc. It makes a humming sound causing:

- unstable arc
- oxidation of weld metal
- poor fusion and penetration
- poor control of molten metal
- more spatters, indicating wastage of electrode metal.

It is used in plug and slot welding, for restarting the arc and while withdrawing the electrode at the end of a bead after filling the crater. Generally long arc is to be avoided as it will give a defective weld.

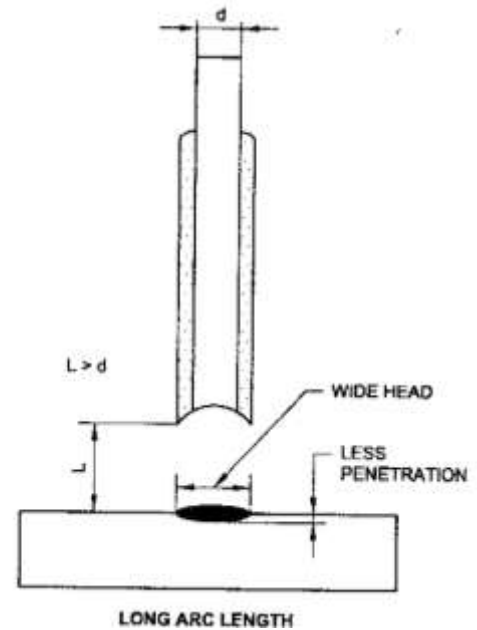

2.5.3 Short Arc

If the distance between the tip of the electrode and the base metal is less than the diameter of the core wire, it is called a short arc. It makes a popping sound causing:

- the electrode melting fastly and trying to freeze with the job
- higher metal with narrow width bead
- less spatters
- more fusion and penetration.

It is used for root runs to get good root penetration, for positional welding and while using a heavy coated electrode, low hydrogen, iron, powder and deep penetration electrode.

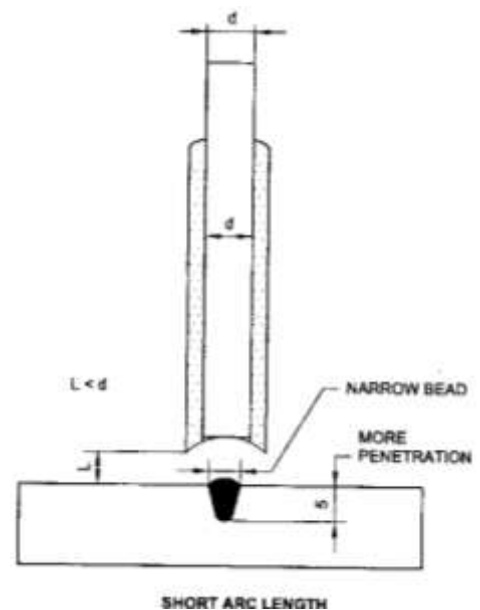

2.6 SAFETY IN MANUAL METAL ARC WELDING

During arc welding the welder is exposed to hazards such injury due to harmful rays (ultra violet and infra red rays) of the arc, burns due to excessive heat from the arc and contact with hot jobs, electric shock, toxic fumes, flying hot spatters and slag particles and objects falling on the feet.

The following safety apparels and accessories are used to protect the welder and other persons working near the welding area from the above mentioned hazards.

1. Safety apparels

- a. Leather apron
- b. Leather gloves
- c. Leather cape with sleeves
- d. Industrial safety shoes

2. Hand screen

- a. Adjustable helmet
- b. Portable fire proof canvas screens

3. Chipping/ grinding goggles

4. Respirator and exhaust ducting

2.6.1 Safety Apparels

The leather apron, gloves, cape with sleeves and leg guard are used to protect the body, hands, arms, neck and chest of the welder from the heat radiation and hot spatters from the arc and also from the hot slag particles flying from the weld joint during chipping off the solidified slag.

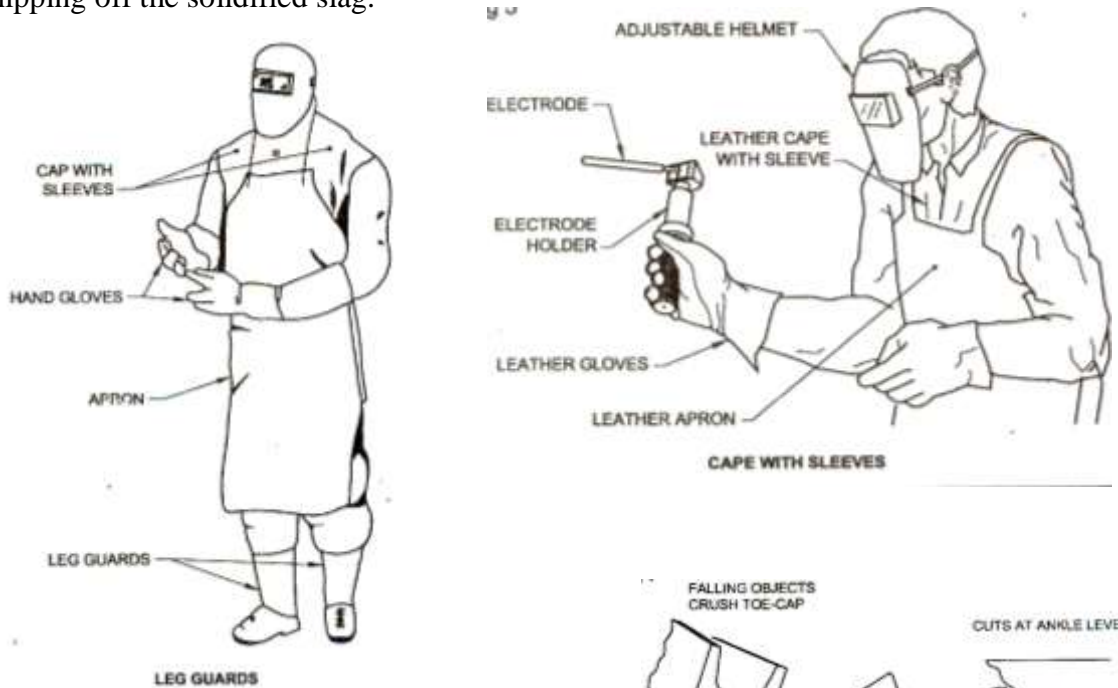

All the above safety apparels should not be loose while wearing them and suitable size has to be selected by the welder.

The industrial safety boot is used to avoid slipping, injury to the toes and ankle of the foot.

It also protects the welder from the electric shock as the sole of the shoe is specially made of shock resistant material.

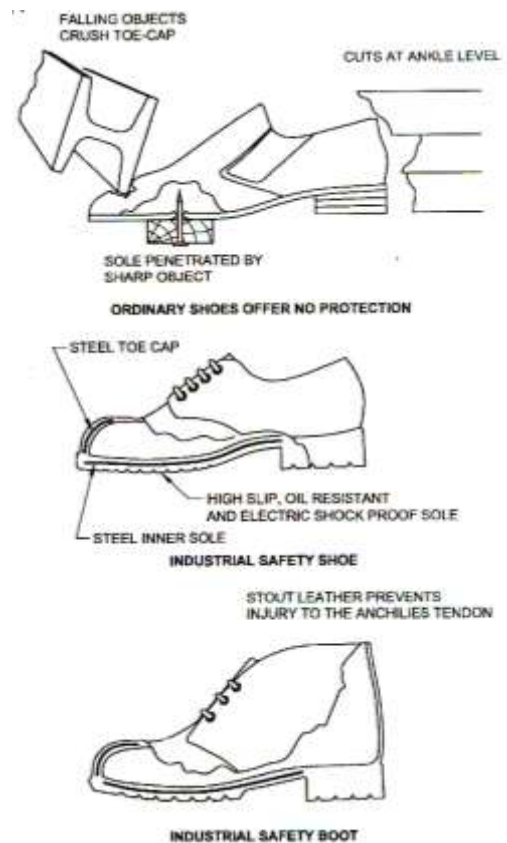

2.6.2 Welding Hand Screens and Helmet

These are used to protect the eyes and face of a welder from arc radiation and sparks during arc welding.

A hand screen is designed to hold in hand. A helmet screen is designed to wear on the head. It provides better protection and allows the welder to use his both hands freely.

Screens are made of non-reflective, non-flammable, insulated, dull coloured, light material with coloured (filter) glasses fitted with plain glasses on both sides to see the arc and molten pool while welding. Clear glasses are fitted on each side of the coloured glass to protect it from weld spatters.

Coloured (filter) glasses are made in various shades depending on the welding current ranges used as given below:

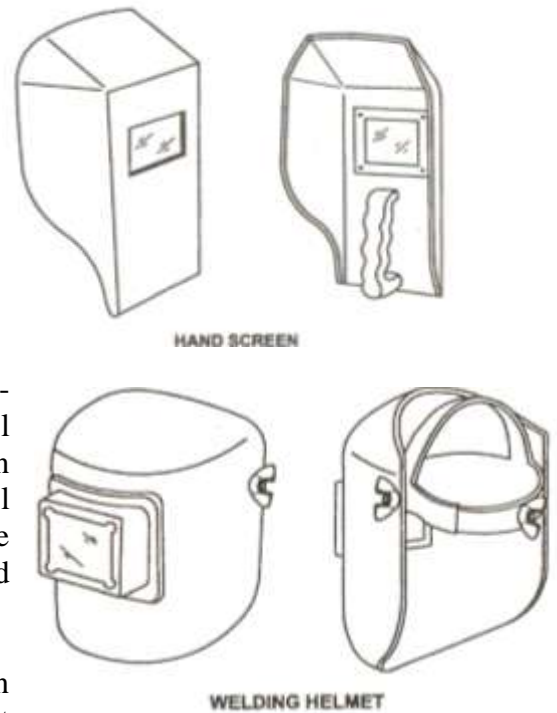

Recommendation of filter glasses for manual metal arc welding

Shade No. of coloured glass	Range of welding current in amperes
8-9	Upto 100
10-11	100 to 300
12-14	Above 300

Portable fire proof canvas screens are used to protect the persons who work near the welding area from arc flashes.

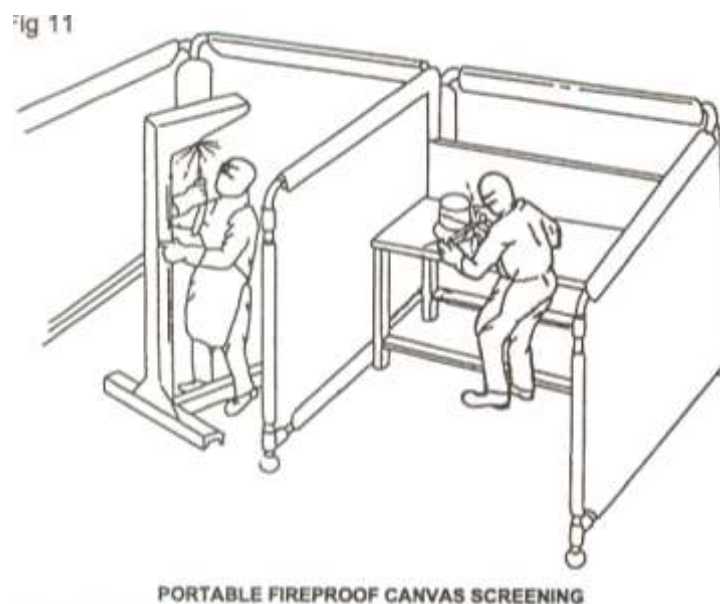

Plain goggles are used to protect the eyes while **chipping** the slag or **grinding** the job. It is made of Bakelite frame fitted with clear glasses and an elastic band to hold it securely on the operators head. It is designed for comfortable fit, proper ventilation and full protection from all sides.

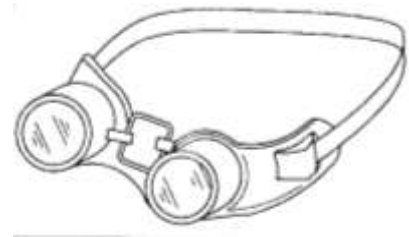

2.7 ARC WELDING ACCESSORIES

Some very important items used by a welder with an arc welding machine during the welding operation, are called arc welding accessories.

2.7.1 Electrode-Holder

It is a clamping device used to grip and manipulate the electrode during arc welding. It is made of copper/ copper alloy for better electrical conductivity. Partially or fully insulated holders are made in various sizes i.e. 200-300-500 amps.

The electrode-holder is connected to welding machine by a welding cable.

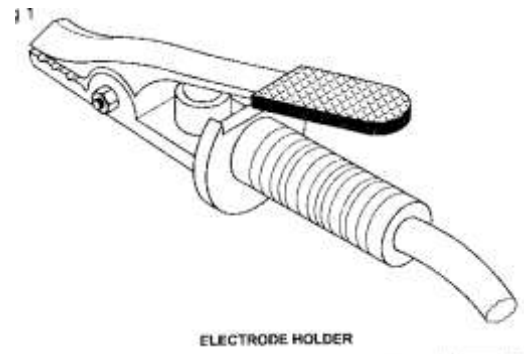

2.7.2 Earth Clamp

It is used to connect the earth cables firmly to the job or welding table. It is also made of copper/ copper alloys. Screw or spring loaded earth clamps are made in various sizes i.e. 200-300-500 amps.

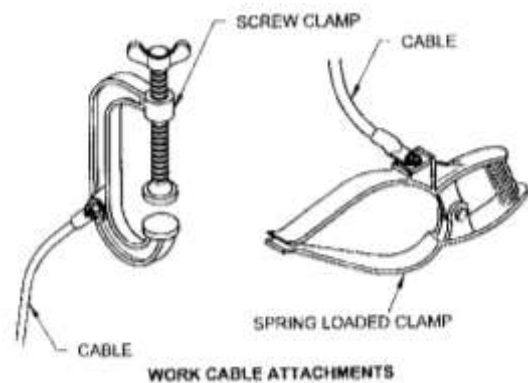

2.7.3 Welding Cables/ Leads

These are used to carry the welding current from the welding machine to the work and back. The lead from the welding machine to the electrode-holder is called electrode cable and the lead from the work or job through the earth clamp to the welding machine is called earth (ground) cable.

Cables are made of super flexible rubber insulation, having fine copper wires and woven fabric reinforcing layers. Welding cables are made in various sizes (cross-sections) i.e. 300, 400, 600 amps etc.

The same size welding cables must be used for the electrode and the job. The cable connection must be made with suitable cable attachments (lugs). Loose joints or bad contacts cause overheating of the cables.

2.8 MATERIAL PREPARATION METHOD

2.8.1 Cutting

Cutting and preparing the base metal to the required dimensions from the original material available is necessary before welding them. Different methods used to cut metals are:

1. By chiseling the sheets
2. By hack-sawing
3. By shearing using hand lever shear
4. By using guillotine shear
5. By gas cutting

For thin sheets the first 4 methods are used. For thick materials method 2, 4 and 5 are used.

Tools and equipments used to cut metals:

1. Cold chisel
2. Hacksaw with frame
3. Hand lever shear
4. Guillotine shear
5. Oxy-acetylene cutting torch

The cut edges of the sheet or plate are to be filed to removed burrs and to make the edges to be square (at 90° angle) with each other. For ferrous metal plates, which are more than 3mm thick, the edges can be prepared by grinding them on a bench/ pedestal grinding machine.

2.8.2 Cleaning

The base metals before cutting them to size will have impurities like dirt, oil, paint, water and surface oxides, due to long storage. These impurities will affect the welding and will create some defects in the welded joint. So in order to get a strong welded joint, it is necessary to clean the surfaces to be joined and remove the dirt, oil, paint, water, surface oxide etc. from the joining surfaces before welding.

Importance of cleaning

The basic requirement of any welding process is to clean the joining edges before welding. The joining edges or surfaces may have oil, paint, grease, rust, moisture, scale or any other foreign matter. If these contaminants are not removed the weld will become porous, brittle and weak. The success of welding depends largely on the conditions of the surface to be joined before welding.

Methods of cleaning

Chemical cleaning includes washing the joining surface with solvents of diluted hydrochloric acid to remove oil, grease, paint etc.

Mechanical cleaning includes wire brushing, grinding, filing, sand blasting, scraping, machining or rubbing with emery paper.

For cleaning ferrous metals a carbon steel wire brush is used. For cleaning stainless and non-ferrous metals, a stainless steel wire brush is used.

2.9 OPEN CIRCUIT VOLTAGE AND ARC VOLTAGE

Figure given below shows an electric circuit used in arc welding. After switching on the welding machine, when there is no arc created/ struck between the electrode tip and the base metal then the voltage “V” shown by the voltmeter in the circuit is called “**Open circuit voltage**”. The value of this open circuit voltage will vary from 60V to 110V depending on the type of machine.

After switching on the welding machine, if the arc is struck/ created between the tip of the electrode and the base metal then the voltage “V” shown by the voltmeter in the circuit is called “**Arc voltage**”.

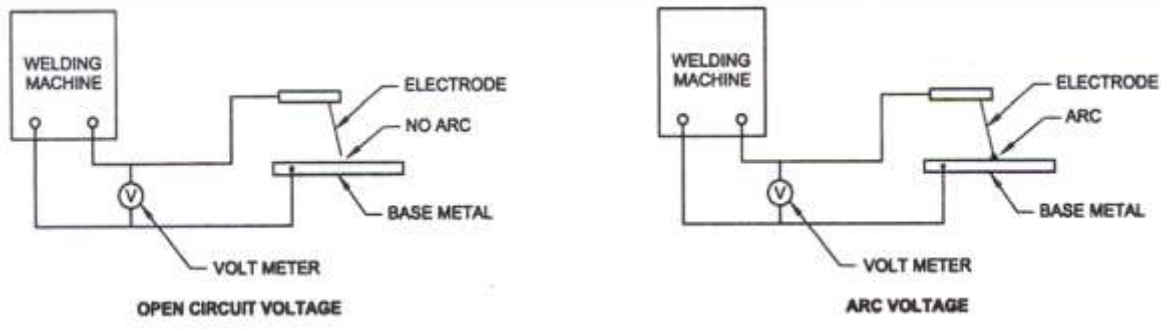

The value of this arc voltage will vary from 18V to 55V depending on the type of machine.

2.10 POLARITY IN DC ARC WELDING

2.10.1 Importance of Polarity in Welding

In DC welding 2/3 of the heat liberated from the positive end and 1/3 from the negative end. To have this advantage of unequal heat distribution in the electrode and base metal, the polarity is an important factor for successful welding.

In AC, the polarity can not be utilized as the power source changes its poles frequently.

Kinds of polarity are two:

- Straight polarity or electrode negative (DCEN).
- Reverse polarity or electrode positive (DCEP).

(i) Straight polarity (DCEN)

In straight polarity the electrode is connected to the negative and the work to the positive terminal of the power source.

Straight polarity is used for:

- welding with bare light coated and medium coated electrodes
- welding the thicker sections in down hand position to obtain more base metal fusion and penetration.

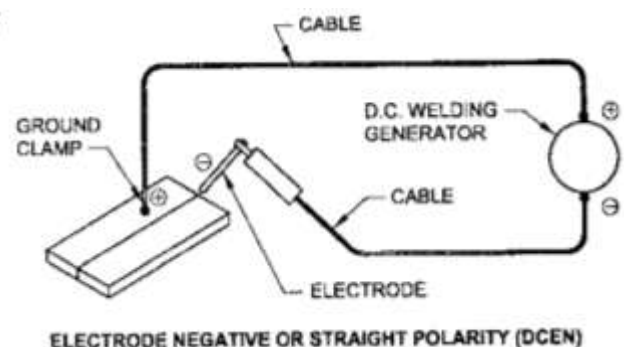

(ii) Reverse polarity (DCEP)

In reverse polarity the electrode is connected to the positive and the work to the negative terminal of the power source. It provides stable arc, low spatter, a good weld bead profile and the greatest depth of root & side wall penetration.

Reverse polarity is used for:

- welding of non-ferrous metals
- welding of cast iron
- welding with heavy and super-heavy coated electrodes
- welding in horizontal, vertical and overhead positions
- sheet metal welding.

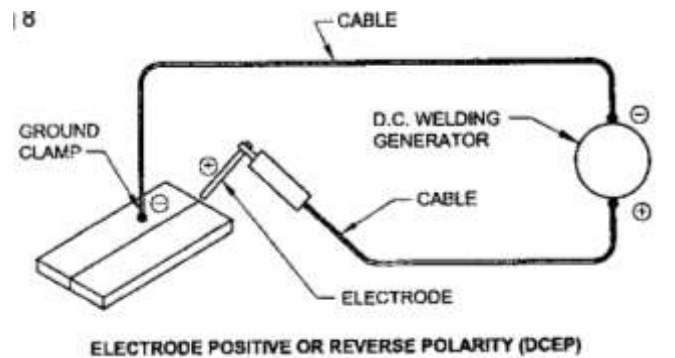

DC is preferred to AC for hard facing and stainless steel welding.

Choice of the polarity also depends on the instruction of the electrode manufacturers.

In order to get the best results, it is essential to attach the electrode with the correct terminal of the welding machine.

2.10.2 Indication of Wrong Polarity

If the electrode is used on wrong polarity it will result in:

- excess spatter and poor penetration
- improper fusion of the electrode
- heavy brownish deposition on the face of the weld metal
- difficulty in manipulation of the arc
- abnormal sound of the arc
- poor weld bead appearance with surface defects and more spatter.

2.11 MILD STEEL WELDING ELECTRODES**2.11.1 Electrode Sizes**

The electrode size refers to the diameter of its core wire. Each electrode has a certain current range. The welding current increases with the electrode size (diameter).

Electrode size	Electrode size
1.6mm	5.0mm
2.0mm	6.0mm
2.5mm	6.3mm
3.15mm	8.0mm
4.0mm	10.0mm

Standard length of electrodes

The electrodes are generally manufactured in the length of 250mm to 450mm.

2.11.2 Functions of an Electrode in Shielded Metal Arc Welding (SMAW)

There are two main functions of an electrode in shielded metal arc welding:

- The core wire conducts the electric current from the electrode holder to the base metal through the arc.
- It deposits weld metal across the arc onto the base metal.

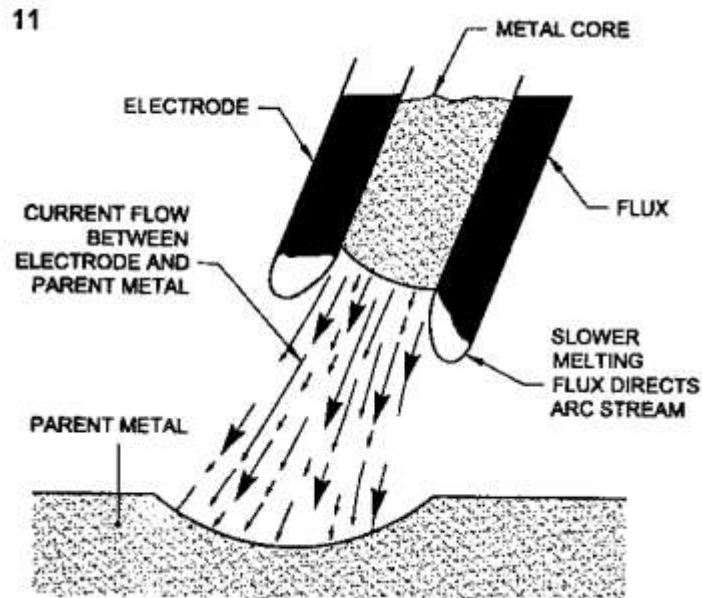

The flux covering melts at a slower rate than the metal core and a cup is formed at the tip of the electrode which helps to direct the molten metal to the required spot.

2.11.3 Identification of Electrodes

For easy identification and selection of a suitable arc welding electrode for welding mild steel plates, the electrodes are coded by Bureau of Indian Standards (**B.I.S.**). According to the B.I.S., the electrodes to be used for welding mild steel for training a beginner is coded as ER4211.

The classification for the electrode ER4211 is given below for easy understanding:

E = Flux coated or covered electrode

R = Type of flux covering (Rutile)

4 = Strength of the joint (UTS = 410-510 N/nm² and YS = 330N/nm² min.)

2 = Elongation and impact properties of the weld
(Elongation = 22% min. and impact = 47 J min. at 0°C)

1 = Welding position (all position) welding can be done in all positions

1 = Welding current and voltage conditions. This means that for DC welding, the electrode can be connected to the +ve or -ve terminal. For AC welding, the open circuit voltage should be 50 volts.

2.11.4 Types of Electrodes

Electric arc welding electrodes are of generally following three types:

- (i) Carbon electrodes
- (ii) Bare electrodes
- (iii) Flux coated electrodes

Carbon electrodes are used in the carbon arc welding process. The arc is created between the carbon electrode and the job. The arc melts a small pool in the job and filler metal is added by using a separate rod.

Normally the carbon arc has very little use of welding. Its main application is in **cutting** and **gouging** operations.

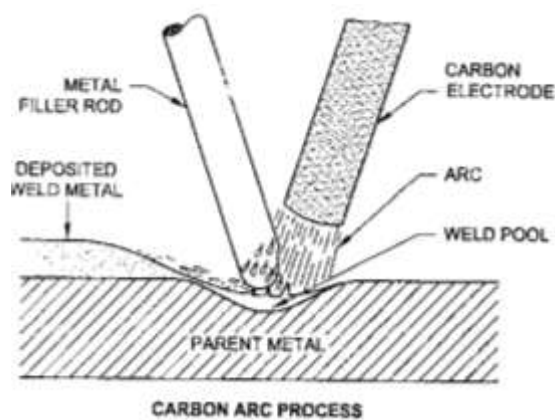

Bare electrodes are also used in some arc welding processes. An inert gas is used to shield the molten weld metal and prevent it from absorbing oxygen and nitrogen. Filler metal is separately added through a filler rod. Usually **tungsten** is used as one of the bare wire electrode. In CO₂ welding and submerged arc welding processes the **mild steel bare wire** electrode is also used as a filler wire.

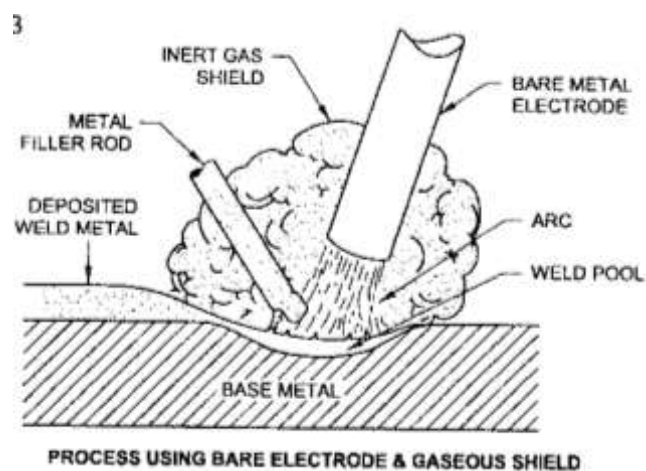

Flux coated electrodes are used in the manual metal arc welding process for welding ferrous and non-ferrous metals. The composition of coating provides the flux, the protective shield around the arc and a protective slag which forms over the deposited weld metal during cooling.

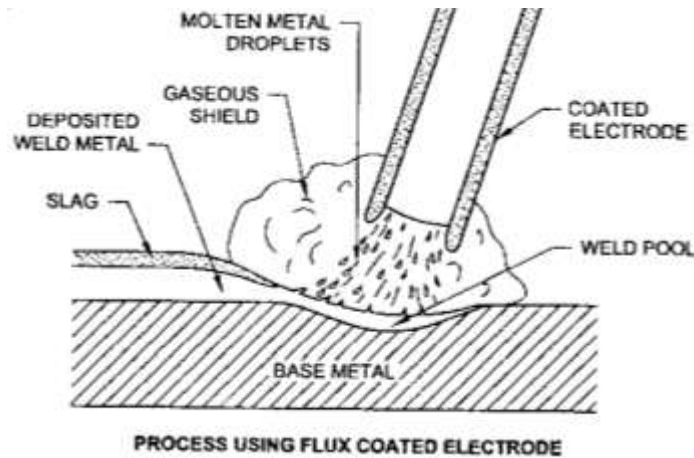

2.12 FLUX COATED ELECTRODES

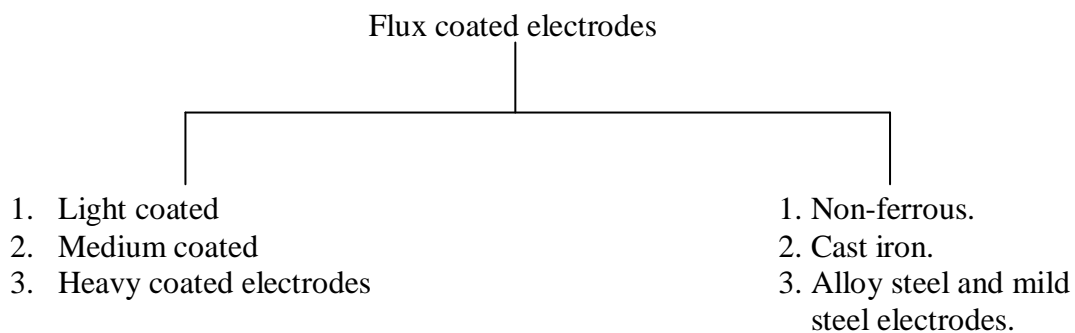

2.12.1 Merits of Flux Coated Electrodes

- A good quality weld is made.
- The arc remains stable.
- The weld penetrates into the job.
- The slag produced during welding reduces the cooling rate of the weld metal.
- Low oxidation.
- Protect the weld metal to become brittle.
- Overhead and vertical welding is easy.
- The spatter loss is low and the bead remains controlled.

2.12.2 Coating Factor

The ratio of electrode dia to the core wire dia is called coating factor.

$$\text{Coating factor} = \frac{\text{Total dia of an electrode}}{\text{Core dia of an electrode}}$$

- a) Light coated electrode coating factor = 1.24 approx.
- b) Medium coated electrode coating factor = 1.44 approx.
- c) Heavy coated electrode coating factor = 1.6 to 2.2

2.12.3 Types of Material used in Flux Coated Electrode

1. Ferro-silicon or Ferro-manganese for de-oxidation of the molten pool.
2. Magnesium silicate, Potassium silicate and Calcium carbonate for obtaining a stable arc.
3. Aluminium silicate, Sodium silicate and magnesium silicate for producing a slag.
4. Wooden sawdust, Cellulose, Calcium carbonate for covering arc.
5. Iron fillings for obtaining a fine arc and uniform bead.

2.12.4 Electrode Coding

At present three methods are for electrode coding:

1. B.S. or BEAMA (British standard or British electrical and Allied Manufacturing Association) method.
2. A.W.S. or A.S.T.M. (American Welding Society or American Society of Testing Material) method.
3. I.S. (Indian Standard) method.

2.13 WELDING MACHINES (POWER SOURCES)

The basic requirements for any arc welding power source are high amperages for welding and relatively low voltage. The first commercially made available welding power source is the **welding transformer**. The commonly used arc welding power sources are as given here.

2.13.1 Welding Transformer

Welding transformer, basically steps down the voltage & hence the output is low voltage high current AC supply. As the output is AC, it has a sinusoidal wave form. Due to its design, it has a lot of circuit power losses like hysterical losses. Thus a welding transformer operates at low efficiency & hence has a low power factor.

Disadvantages of welding with transformer power sources are that with the sinusoidal wave output the current crosses the zero mark twice in a cycle which means

that the arc distinguishes 100 times a second. This produces high weld **spatter**. There is high peak to peak current variation which causes an **unstable arc**. The machine consumes high power during welding & also when machine is ON. The machine is very **economical** for capital investment but the running costs are very high.

For MMAW & TIG welding processes constant current (CC Type) welding transformers are designed. These are available in air cooled & oil cooled versions. The machines are also available in single phase & three phase models from a range of 150A-600A. Welding transformers are also available for aluminium TIG welding as it offers AC output.

These transformers are used by small time fabricators & also by process industries where welding is done for maintenance purposes. However, nowadays rectifiers & inverters are replacing the transformers.

2.13.2 Welding Rectifiers

Welding rectifier provides a DC output by rectifying the low voltage high current AC output obtained from the step down transformer. The output is DC which has a ripple in the DC wave form. With the improvement in transformer design & PCB circuit controls, the rectifier could offer an improved welding quality & better electrical efficiency.

Rectifiers offer a more stable arc & the spatter is considerably low. Even though it has a DC output, the AC content of the sinusoidal wave is imposed in the output as ripples. However, the response time is slow & the output is dependent on the input variations. The machine consumes high power due to its moderate efficiency & power factor.

Welding rectifiers are used for MIG/ MAG, MMAW & TIG welding processes. It is available in constant current (CC Type) and constant voltage (CV Type) power sources. The machines are available in single phase & three phase models from a range of 150A – 1200A. The constant current type of rectifiers can be used for rutile & basic coated electrodes. The constant voltage type of rectifier is used as MIG/ MAG power sources.

Rectifiers are very popular and used by most of the fabricators in the field of automobile, ship building, construction machinery etc.

2.13.3 Welding Generator

Welding generator delivers a pure DC output having no ripple content which produces the most stable welding arcs suitable for MMAW process. The machine design produces a step down voltage with a pure DC output. Generators offer a very stable arc & the spatter is considerably low.

The **disadvantages** of generators are as below:

- High noise level.
- Bulky and hence difficult to transport.
- More moving parts & more wear & tear.
- High maintenance cost due to the design.

Applications

Ideal for MMAW welding and all types of coated electrodes. Very popular machine used in construction industry and particularly for pipe welding applications.

2.13.4 Welding Inverters

Welding inverters are the boon to the welding industry. The technology provides best quality of welding, birth to new welding processes, power efficient, light weight etc.

The 3 phase AC input supply is inverted to DC by a rectifier. This high voltage DC is converted to high frequency AC (HFAC) by a transistor switching device. HFAC is stepped down by a transformer & inverted again by a rectifier to get a DC output.

A 50Hz AC supply when rectified will produce high ripple content in the resultant DC, whereas a high frequency AC at 20 KHz and above will produce an almost straight line DC output, HFAC is produced by IGBT (Isolated Gate Bipolar Transistor) or MOSFET (Metal Oxide Semiconductor Field Effect Transistor) type of switching devices.

The **distinctive advantages** of inverter based welding power sources are:

- Excellent welding characteristics
- Quick response time & constant output supply
- Improved features for welding applications
- Energy efficient due to its high power factor & efficiency
- Low weight & hence easy to transport.

Inverter technology power sources are available for MMAW, TIG, MIG/ MAG, PLASMA and many other processes. Inverters are available with Analogue controls & Digital controls.

CHAPTER 3

OXY- ACETYLENE GAS WELDING

3.1 GAS WELDING

This term relates to a group of welding processes wherein weld is produced by heating with a gas flame or flames, with or without application of pressure and with or without the use of filler wire.

The most common gases are oxygen and acetylene, certain fuel gases hydrogen, LPG, Coal gas etc. are used.

3.2 OXY-ACETYLENE WELDING

Oxy-acetylene welding is a method of joining metals by heating them to the melting point using a mixture of oxygen and acetylene gases.

3.2.1 Acetylene

Acetylene is a fuel gas which produces a very high temperature flame with the help of oxygen because it has more amount of carbon (92.3%) than any other fuel gas. Its chemical symbol is $C_2 H_2$ and composed of:

- Carbon 92.3% (24 parts)
- Hydrogen 7.7% (2 parts)

It is a colourless gas, lighter than air and highly inflammable and burns with a brilliant flame. Commercial acetylene has pungent odour because of certain impurities. It forms a long range of explosive mixture with air any percentage between 3 x 80 becoming explosive on ignition. It may also explode when under unduly high pressure even in absence of air, when mixed with oxygen it explodes more violently. Acetylene absorbs heat during producing and liberates heat when decomposed.

There are two type of acetylene generators:

- Water – to – Carbide generators.
- Carbide – to – Water generators.

Dissolved acetylene means compressed acetylene pumped into steel cylinder filled with porous filling material soaked in acetylene.

3.2.2 Oxygen

Oxygen is a supporter of combustion. Its chemical symbol is O_2 . It is a clear, colourless, odourless and tasteless gas. It is slightly soluble in water. It does not burn itself, but supports combustion of fuels. It is industrially produced by two methods:

- by air liquefaction.
- by electrolysis of water.

3.3 OXY-ACETYLENE WELDING EQUIPMENT AND ACCESSORIES

3.3.1 Oxygen gas Cylinders

The oxygen gas required for gas welding is stored in bottle shaped cylinders. These cylinders are painted in **black colour**. Oxygen cylinders can store gas to a capacity of 7m^3 with the pressure ranging between 120 to 150 kg/cm^2 . Oxygen gas cylinder valves are **right hand threaded**.

3.3.2 Dissolved Acetylene Cylinders

The acetylene gas used in gas welding is stored in steel bottle shaped cylinders painted in **maroon colour**. The normal storing capacity of storing acetylene in dissolved state is 6m^3 with the pressure ranging between 15-16 kg/cm^2 .

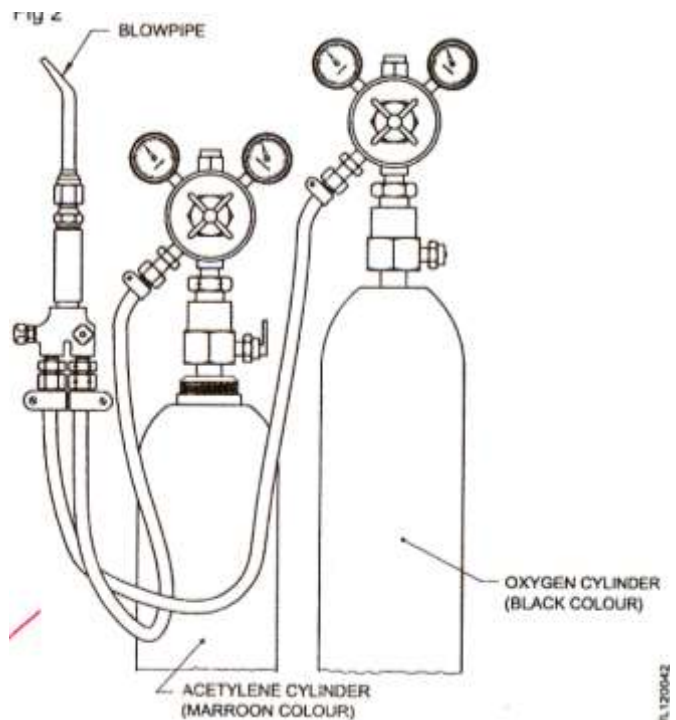

3.3.3 Oxygen Pressure Regulator

This is used to reduce the oxygen cylinder gas pressure according to the required working pressure and to control the flow of oxygen at a constant rate to the blowpipe. The threaded connections are **right hand threaded**.

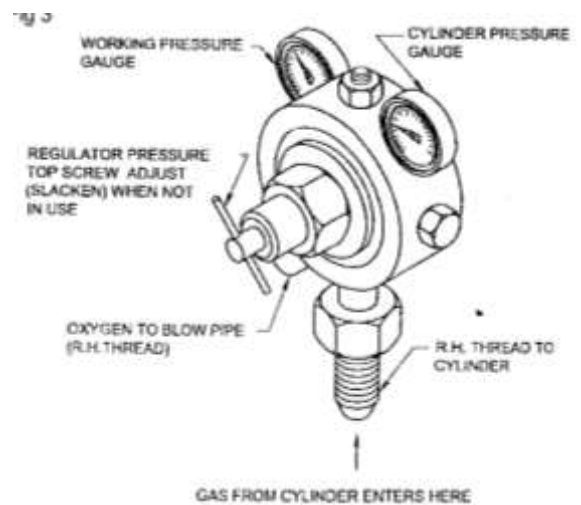

3.3.4 Acetylene Regulator

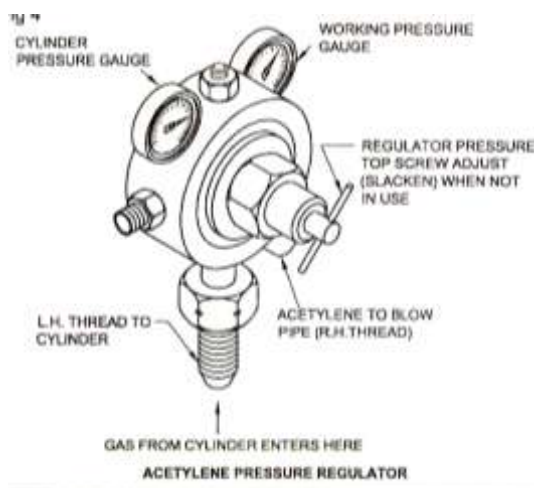

This is also used to reduce the cylinder gas pressure to the required working pressure and to control the flow of acetylene gas at a constant rate to the blowpipe. The threaded connections are **left handed**. For quickly identifying the acetylene regulator, a **groove** is cut at the corners of the nut.

There are two types of regulators

- single stage regulator
- double stage regulator

3.3.5 Rubber Hose Pipes and Connections

These are used to carry gas from the regulator to the blowpipe. These are made of strong canvas rubber having good flexibility. Hose-pipes which carry **oxygen** are **black** in colour and the **acetylene** hoses are of **maroon** colour.

3.3.6 Hose Protectors

At the blowpipes end of the rubber hoses hose-protectors are fitted. The hose protectors are in the shape of a connecting union and have a non-return disc fitted inside to protect from flashback and backfire during welding.

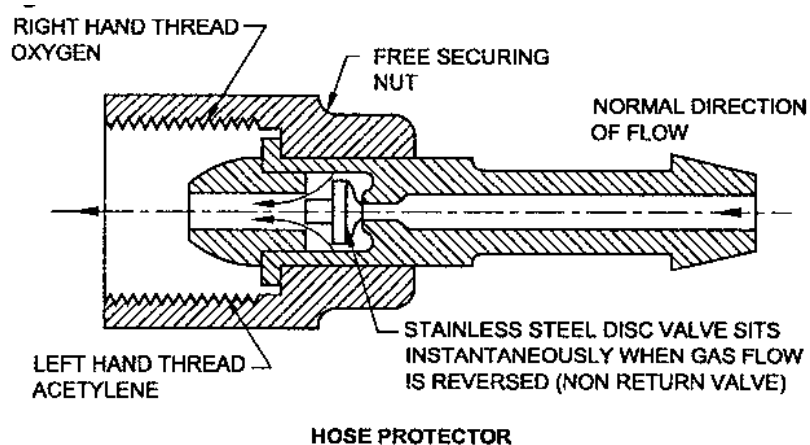

3.3.7 Blowpipe and Nozzle

Blowpipes are used to control and mix the oxygen and acetylene gases to the required proportion.

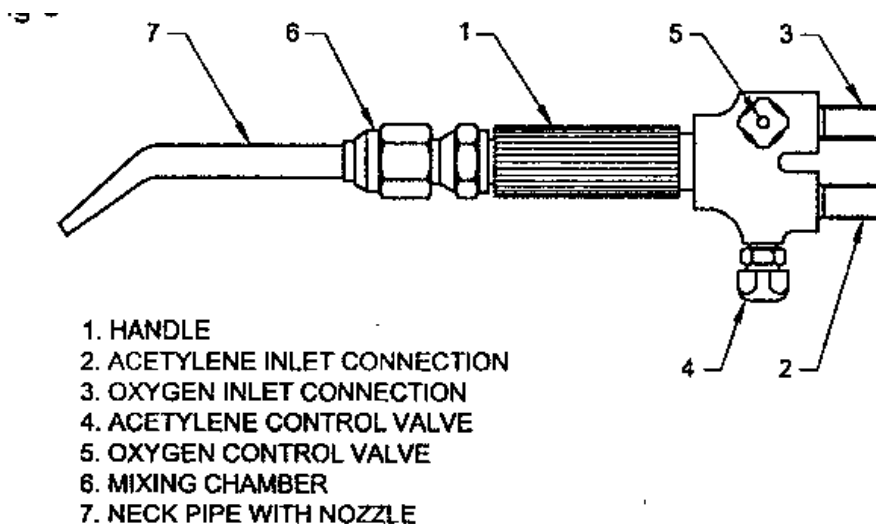

A set of interchangeable nozzles/ tips of different sizes is available to produce smaller or bigger flames.

The size of the nozzle varies according to the thickness of the plates to be welded.

Plate thickness	Nozzle size
mm	number
0.8	1
1.2	2
1.6	3
2.4	5
3.0	7
4.0	10
5.0	13
6.0	18
8.0	25
10.0	35
12.0	45
19.0	55
25.0	70
Over 25.0	90

3.4 SAFETY PRECAUTIONS IN HANDLING OXY-ACETYLENE GAS WELDING PLANT

One must observe safety rules in day-to-day working to avoid accident. **“Accident starts when safety ends.”**

Oxy-acetylene equipment is safe if it is properly handled, but it may become a great destructive power if handled carelessly. It is important that the operator be familiar with all the safety rules before handling gas cylinders.

In gas welding, the welder must follow certain safety precautions while handling gas welding plants in order to prevent accidents to others and him. Observing the following precautions will help the gas welder to avoid accidents to a great extent.

3.4.1 General Safety Precautions

- Never use oil or grease in any part or assembly of a gas welding plant as it may cause an explosion.
- All inflammable materials should be kept away from the welding area.
- Always wear goggles with filter glasses during welding.
- Wear fire-resistant clothes, asbestos gloves and an apron while welding.
- **Never wear nylon or greasy clothes while welding.**
- Rectify the gas leakages noticed immediately as even a small leakage can lead to serious accidents.
- Always keep fire extinguishing devices handy and in working order.
- While leaving the work area, make sure the place is free from any form of fire.

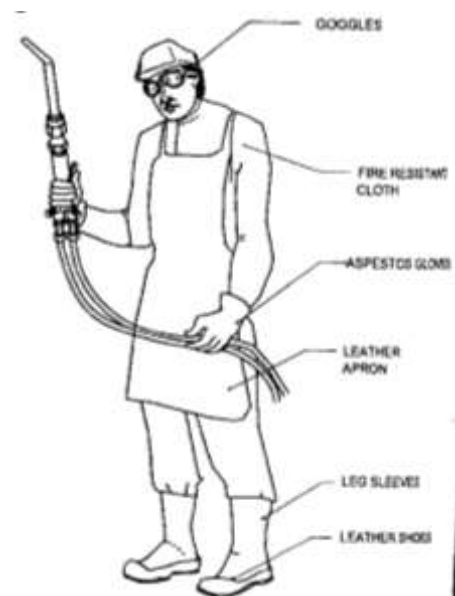

3.4.2 Safety Concerning Gas Cylinders

- Do not roll gas cylinders for shifting. Always use a trolley to carry cylinders.
- Do not drop the gas cylinders.
- Close the cylinder valves when not in use or empty.
- Keep the empty cylinders and full cylinders separately.
- Always open the cylinder valves slowly and not more than one and a half turn.
- Use always the correct size cylinder keys.
- Stand aside when opening the cylinders.
- Do not remove the cylinder keys from the cylinders during welding. It will help to close the cylinders quickly in case of an emergency.
- Always keep the cylinders in an upright position keeping in view safety and ease in handling.
- Always crack the cylinder valves to clean the valve socket before attaching the regulators.
- Never fall or trip over gas cylinders.
- A valve broken in the oxygen cylinder will cause it to become a rocket with tremendous force.
- Keep the gas cylinders away from exposure to high temperature.
- Remember the pressure in the gas cylinders increases with the temperature.
- Mark the empty cylinders (MT/EMPTY) with chalk.
- Put on the valve protection caps when the cylinders are not in use or they are being moved.
- Close the cylinder valves both when they are full and empty.
- Never remove the valve protection cap while lifting cylinders.
- Avoid exposing the cylinders to furnace heat, open fire or sparks from the torch.
- Smoking or naked lights should be strictly prohibited near gas cylinders.
- Never strike an arc of direct gas flame on a gas cylinder.

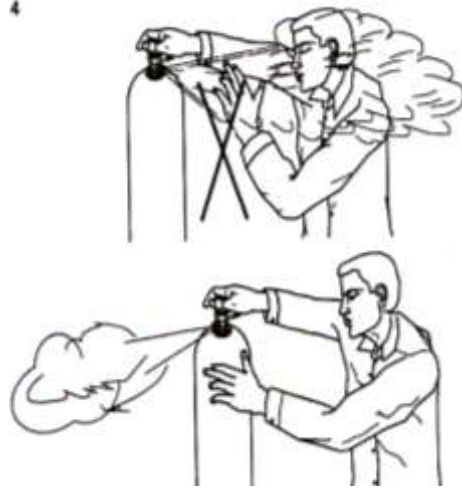

BLOW OUT THE CYLINDER VALVE SOCKET BEFORE CONNECTING THE REGULATOR CRACKING OPEN THE CYLINDER VALVE MOMENTARILY



3.4.3 Safety of Rubber Hose-Pipes

- Use only the type of hose recommended for use in gas welding.
- Use only black coloured hoses for oxygen and maroon coloured ones for acetylene gas.
- Avoid damage to the hose-pipes caused by rubbing against hard or sharp edges.
- Ensure that the hoses do not cross the gangways.
- Do not add bits of hose together to make up the length.
- Blow out the hose-pipes before connecting to the blowpipe to remove dirt or dust.
- Protect the regulators from water, dust, oil etc.
- Never attempt to interchange oxygen and acetylene regulators while fitting as it can damage the threads.
- Always remember the **oxygen connection is right-hand threaded** and the **acetylene connections have left hand threads**.
- In the event of backfire shut both the blowpipe valves (**oxygen first**) quickly and dip the blowpipe in water.
- While igniting the flame, point the blowpipe nozzle in a safe direction and use the spark lighter to ignite the flame to avoid fire hazards.
- While extinguishing the flame, shut off the acetylene valve first and then the oxygen to avoid backfire.
- Check for leakage before using oxy-acetylene welding equipment.

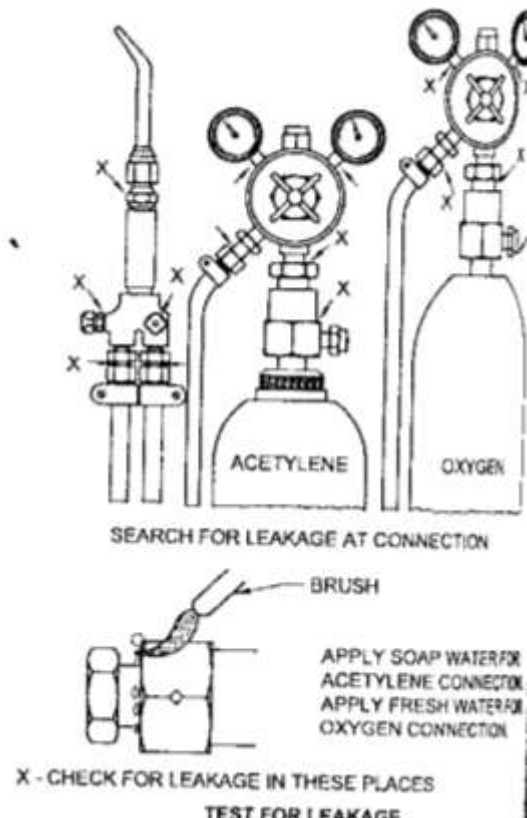
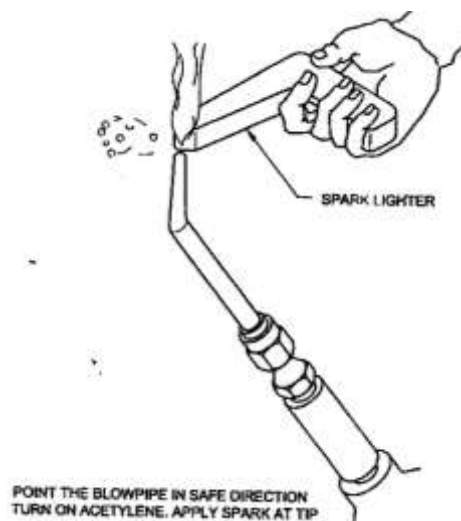
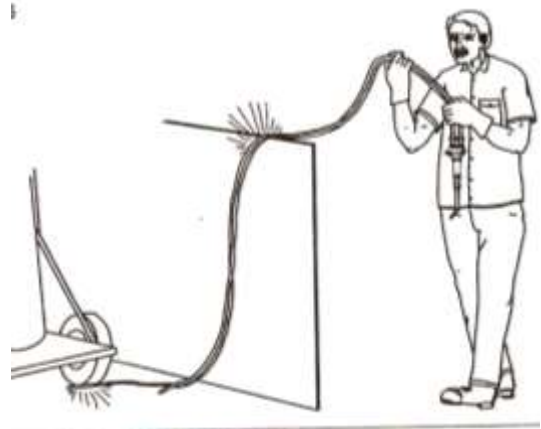

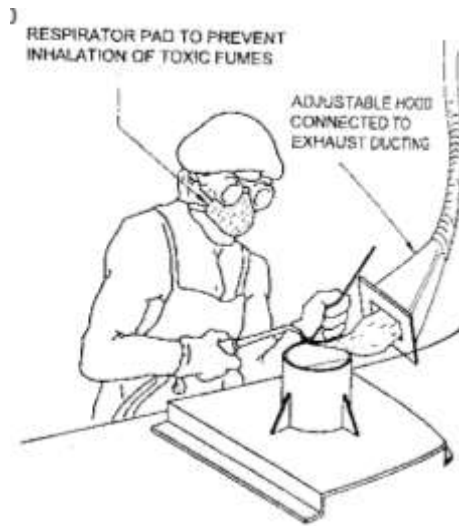

- Toxic and poisonous fumes given out during welding of some materials should be collected and cleared so as to be prevented from inhaling. For this an exhaust ducting and a respirator may be used.

- Containers used for the storage of flammable materials should not be welded without **thorough cleaning** as otherwise the containers may explode.

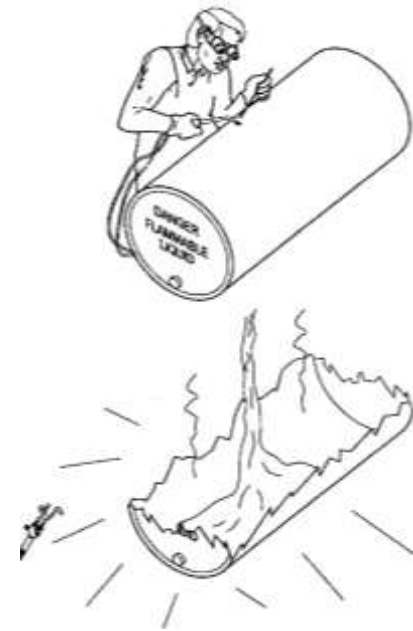

3.5 TROUBLE WITH BLOW PIPE & CYLINDERS

3.5.1 Backfire

At certain times during ignition in gas welding a small explosion of the flame occurs at the torch tip. The flame may or may not go off. This is known as '**backfire**'.

Causes: A backfire is caused when:

- the gas pressure setting is low
- the nozzle is overheated
- the nozzle orifice is blocked by carbon or spark deposits
- the nozzle touches the molten pool
- there is leakage near the nozzle

Eliminate the causes before proceeding further to avoid backfire.

3.5.2 Flashback

Sometimes during backfire, the flame goes off and the burning acetylene gas travels backward in the blowpipe, towards the regulator or cylinders. This is known as '**flashback**'.

Indications of flashback:

- A sharp squealing sound inside the blowpipe may be heard.
- Heavy black smoke and sparks come out of the nozzle.
- The blowpipe handles starts heating.

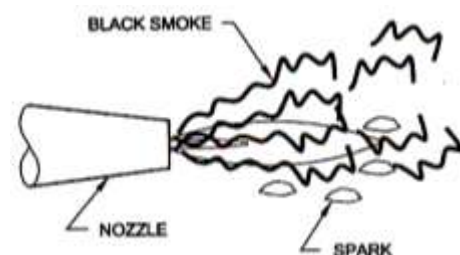

Immediate steps:

- Close the blowpipe valves (**oxygen first**)
- Immerse the blowpipe in water and close the cylinder valves.

If the backfire or flashback is not checked in time, it may cause serious accidents to men and machines.

3.5.3 Cylinder Catches Fire

If the cylinder catches fire externally due to the leakage of gas at the connection:

- close the cylinder valve immediately (wearing asbestos gloves as a safety measure)
- use carbon dioxide fire extinguisher to extinguish the fire.
- Rectify the leakage thoroughly before putting into further use.

If the cylinder becomes overheated due to internal or external fire:

- close the cylinder valve
- detach the regulator from the cylinder
- remove the cylinder to an open space, away from smoking or naked light.
- Cool the cylinder by spraying with water
- Inform the gas cylinder supplier immediately
- Never keep such defective cylinders with the other cylinders.

3.6 TYPES OF OXY-ACETYLENE FLAMES

The oxy-acetylene gas flame has following features which make it useful for gas welding:

- it has a well controlled flame with high temperature
- the flame can be easily manipulated for proper melting of the base metal
- it does not change the chemical composition of the base metal/ weld.

Three different types of oxy-acetylene flames as given below can be set:

- Neutral flame
- Oxidising flame
- Carburizing flame

3.6.1 Neutral Flame

Oxygen and acetylene are mixed in equal proportion in the blowpipe and complete combustion takes place in this flame. This flame does not have a bad effect on the metal/ weld i.e. the metal is not oxidized and no carbon is available for reacting with the metal.

It is used to weld most of the common metals, i.e. mild steel, cast iron, stainless steel, copper and aluminium.

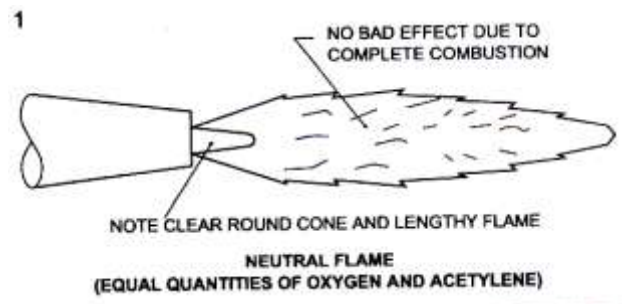

3.6.2 Oxidizing Flame

It contains an excess of oxygen over acetylene as the gases come out of the nozzle. The flame has an oxidizing effect on metals which prevents evaporation of zinc/ tin in brass welding/ brazing.

It is used for welding of brass and for brazing of ferrous metals.

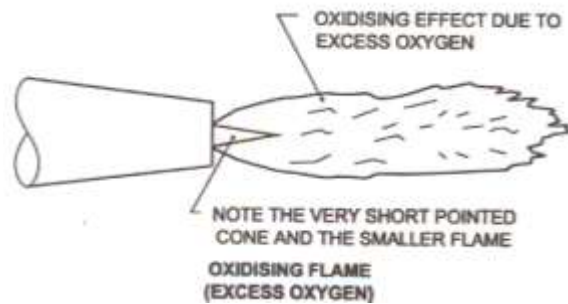

3.6.3 Carburizing Flame

It receives an excess of acetylene over oxygen from the blowpipe. The flame has a carburizing effect on steel, causing hard, brittle and weak weld.

It is Useful for stellite (hard facing), 'Linde' welding of steel pipes, and flame cleaning.

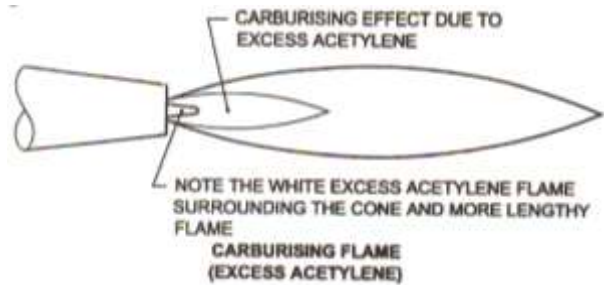

The selection of the flame is based on the metal to be welded. The neutral flame is the most commonly used flame. Metals and flame to be used are as given below:

Metal	Flame
• Mild steel	Neutral
• Copper (de-oxidised)	Neutral
• Brass	Oxidising
• Cast iron	Neutral
• Stainless steel	Neutral
• Aluminium (pure)	Neutral
• Stellite	Carburising

3.6.4 Chemistry of Oxy-acetylene Flame

Oxy-acetylene flame is produced by the combustion of a mixture of oxygen and acetylene in various proportions. The temperature and characteristics of the flame depend on the ratio of the two gases in the mixture.

Features of neutral flame

Oxy-acetylene flame consists of the following features by appearance:

- Inner core
- Inner reducing zone
- Outer zone or envelope

Different zones and temperature

To know and make the best use of oxy-acetylene flame, the temperature in different zones is shown below:

The greatest amount of heat is produced at just ahead of the inner cone called the **hottest point** or region of maximum temperature.

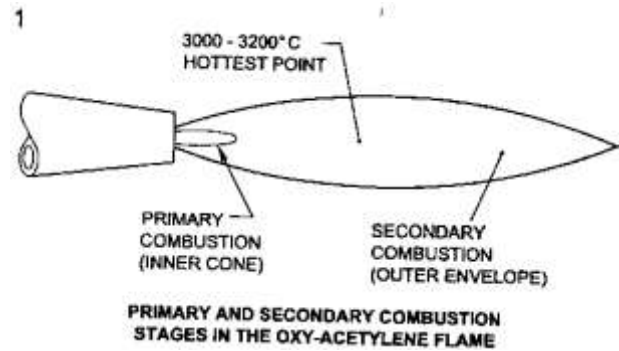

Combustion ratio of oxygen and acetylene in flame

For complete combustion/ burning one volume of acetylene requires two and a half volumes of oxygen.

Acetylene	:	Oxygen
1 litre	:	2.5 litres

Equal volumes of acetylene and oxygen are supplied from the blowpipe to produce a **neutral flame**

Acetylene	:	oxygen
1 litre	:	1 litre
(Primary combustion)		

So another 1.5 litres of oxygen is required for complete burning of acetylene. The flame takes an additional 1.5 litres of oxygen from the surrounding atmosphere (secondary combustion)

3.7 FILLER RODS FOR GAS WELDING

3.7.1 Filler Rod and its Necessity

Pieces of wires or rods of standard diameter and length used as filler metal in the joint during gas welding process are called filler rods or welding rods. These rods are made out of ferrous or non-ferrous metal.

To obtain best results, high quality filler rods should be used. The actual cost of welding rods is very small compared with cost of job, labour, gases and flux.

Good quality filler rods are necessary to:

- reduce oxidation (effect of oxygen)
- control the mechanical properties of the deposited metal
- make up for the loss of certain elements in the weld metal caused by fusion.

While welding, a cavity or depression will be formed at the joints of thin section metals. For heavy/ thick plates a groove is prepared at the joint. This groove is necessary to get better fusion of the full thickness of the metal, so as to get a uniform strength at the joint. This groove formed has to be filled with metal. For this purpose also a **filler rod** is necessary. Each metal requires a suitable filler rod.

3.7.2 Sizes as Per IS:1278-1972

The size of the filler rod is determined from the diameter as: 1.00, 1.20, 1.60, 2.00, 2.50, 3.15, 4.00, 5.00 and 6.30 mm.

For leftward technique filler rods upto 4 mm dia. are used. For rightward technique upto 6.3 mm dia. is used. For cast iron welding filler rods of 6 mm dia. and above are used.

Length of filler rod are 500 mm or 1000 mm.

Filler rods above 4 mm diameter are not used often for welding of mild steel. The usual size of mild steel filler rods used are 1.6 mm and 3.15 mm diameter. All mild steel filler rods are given a thin layer of copper coating to protect them from oxidation (rusting) during storage. So these filler rods are called **copper coated mild steel (C.C.M.S)** filler rods.

All types of filler rods are to be **stored in sealed plastic covers** until they are used.

3.7.3 Types of Filler Rods

The following types of filler rods are classified in gas welding:

- Ferrous filler rod
- Non-ferrous filler rod
- Alloy type filler rod for ferrous metals
- Alloy type filler rod for non-ferrous metals

A ferrous type filler rod has a major % of iron.

The **ferrous type filler** rod contains iron, carbon, silicon, sulphur and phosphorous.

The **alloy type filler** rod contains iron, carbon, silicon and any one or many of the elements such as manganese, nickel, chromium, molybdenum etc.

The **non-ferrous filler** rod is a filler rod which contains elements of non-ferrous metals. The composition of non-ferrous type filler rods is similar to any non-ferrous metal such as copper, aluminum.

A non-ferrous alloy type filler rod contains metal like copper, aluminium, tin etc. alongwith zinc, lead, nickel, manganese, silicon, etc.

3.7.4 Selection of the Filler Rod

Selection of the correct filler rod for a particular job is a very important step for successful welding. Composition of filler metal is chosen with special consideration to the metallurgical requirement of a weldment.

A wrong choice due to either ignorance or a false consideration of economy may lead to costly failures. **IS:1278-1972** specifies requirements that should be met by filler rods for gas welding. There is another specification **IS:2927-1975** which covers brazing alloys.

It is strongly recommended that filler material conforming to these specifications is used. In certain rare cases, it may be necessary to use filler rods of composition not covered by these specifications; in such cases filler rods with well established performance should be used.

To select a filler rod in respect to the metal to be welded, the filler rod must have the same composition with respect to the base metal to be welded.

Factors to be considered for selection of filler rod are:

- a. the type and composition of base metal
- b. the base metal thickness
- c. the type of edge preparation
- d. the weld is deposited as root run, intermediate runs or final covering run
- e. welding position
- f. whether there is any corrosion effect or loss of material from the base metal due to welding.

3.7.5 Care and Maintenance

- Filler rods should be stored in clean, dry condition to prevent deterioration.
- Do not mix different types of filler rods.
- Ensure that packages and their labels are in order for easy and correct selection.
- Where it is not practicable to store filler rods under heated conditions, an absorbent for moisture such as silica-gel may be used in the storage area.
- Ensure the rod is free from contamination such as rust, scale, oil, grease and moisture.
- Ensure the rod is reasonably straight to assist manipulation during welding.

3.7.6 Different Filler Metals and Fluxes for Gas Welding

Filler metal type	Applications	Flux
Mild steel-type S-FS1	A general purpose rod for welding mild steel where a minimum butt-weld tensile strength of 35.0 kg/mm ² is required. (Full fusion technique with neutral flame).	Not required
Mild steel-Type S-FS2	Intended for application in which minimum butt-weld tensile strength of 44.0kg/mm ² is required. (Full fusion technique with neutral flame).	Not required
Wear resisting alloy steel	Building up worn out crossings and other application where the steel surfaces are subject to extreme wear by shock and abrasion. (Surface fusion technique with excess acetylene flame)	Not required
3 % nickel steel Type S-FS4	These rods are intended to be used in repair and reconditioning parts which have to be subsequently hardened and tempered. (Full fusion technique with neutral flame)	special flux (If necessary)
Stainless steel decay-resistant (niobium bearing) Type S-Bo2MoNb	These rods are intended for use in the welding of corrosion-resisting steels such as those containing 18% chromium and 8% nickel. (Full fusion technique with neutral flame).	Necessary
High silicon cast iron-Type S-C11	Intended for use in the welding of cast iron where an easily achievable deposit is required. (Full fusion technique with neutral flame).	Flux necessary
Copper filler rod – Type S-C1	For welding of de-oxidized copper (Full fusion technique with neutral flame).	Flux necessary
Brass filler rod-Type S-C6	For use in the braze welding of copper and mild steel and for the fusion welding of material of the same or closely similar composition. (Oxidising flame)	Flux necessary
Manganese bronze (high tensile brass) – Type S-C8	for use in braze welding of copper, cast iron and malleable iron and for the fusion welding of materials of the same or closely similar composition (Oxidising flame)	Flux necessary

Filler metal type	Applications	Flux
Medium nickel bronze-Type S-C9	For use in the braze welding of mild steel, cast iron and malleable iron (Oxidising flame)	Flux required.
Aluminium (Pure) -Type S-C13	For use in the welding of aluminum grade 1B. (Full fusion technique with neutral flame).	Flux necessary
Aluminium alloy - 5% silicon – Type S-NG 21	For welding of aluminium casting alloys, except those containing magnesium or zinc as the main addition. They may also be used to weld wrought aluminium-magnesium-silicon alloys. (Full fusion technique with neutral flame).	Flux necessary.
Aluminium alloy- 10-13% silicon – Type 5-NG2	For welding high silicon aluminium alloys. Also recommended for brazing aluminium. (Neutral flame)	Flux necessary
Aluminium alloy 5% copper	For welding aluminium casting particularly those containing about 5% copper. (Full fusion technique with neutral flame)	Flux necessary.
Stellite: Grade 1	Hard facing of components subjected mainly to abrasion. (Surface fusion technique with excess acetylene flame)	None is usually required. A cast iron flux may be used, if necessary.
Stellite: Grade 6	Hard facing of components subjected to shock and abrasion. (surface fusion technique with excess acetylene flame)	-do-
Stellite: Grade 12	Hard facing of components subjected to abrasion and moderate shock. (Surface fusion technique with excess acetylene flame)	-do-
Copper phosphorous brazing alloy-Type BA-CuP2	Brazing copper, brass and bronze components. Brazing with slightly oxidizing flame on copper; neutral flame on copper alloys.	necessary
copper-phosphorous brazing alloy – Type BA-CuP5	For making ductile joint in copper without flux. Also widely used on copper based alloys of the brass and bronze type in conjunction with a suitable silver brazing flux. (Flame slightly oxidizing on copper; neutral on copper alloys)	None for copper. A flux is necessary for brazing copper alloys.

Filler metal type	Applications	Flux
Silver-copper-zinc (61% silver) type brazing alloys-type BA-CuP3	Similar to type BA-CuP5 but with a slightly lower tensile strength and electrical conductivity (flame slightly oxidizing on copper; neutral on copper alloys). NOTE: Phosphorous bearing silver brazing alloys should not be used with ferrous metal or alloys of high nickel content.	None for copper. A flux is necessary for brazing copper alloys.
Silver-copper-zinc (61% silver) - type BA-Cu-AG6	This brazing alloy is particularly suitable for joining electrical components requiring high electrical conductivity. (Flame neutral)	Flux necessary.
Silver-copper-zinc (43% silver)-type BA-Cu-Ag16	This is a general purpose brazing alloy and is particularly suitable for joining electrical components requiring high electrical conductivity. (Flame neutral)	Flux necessary
Silver-copper-zinc-cadmium (43% silver) type BA-Cu-Ag16A	An ideal composition for economy in brazing operation requiring a low temperature, quick and complete penetration. Suitable on steel, copper, copper, brass, bronze, copper-nickel alloys and nickel silver. (Flame neutral)	Flux necessary
Silver-copper-zinc-cadmium (50% silver) type BA-Cu-Ag11	This alloy is also suitable for steel, copper-nickel alloys and nickel-silvers. (Flame neutral)	Flux necessary.
Silver-copper-zinc-cadmium-nickle (50% silver) type BA-Cu-Ag12	Specially suitable for brazing tungsten carbide tips to rock drills, milling cutters, cutting and shaping tools; also suitable for brazing steels which are difficult to 'wet' such as stainless steels. (Flame neutral)	Flux necessary.

3.8 WELDING TECHNIQUES OF OXY-ACETYLENE WELDING

There are following two welding techniques used in oxy-acetylene welding process:

1. Leftward welding technique (Forehand technique)
2. Rightward welding technique (Backhand technique)

3.8.1 Leftward Welding Technique

It is the most widely used oxy-acetylene gas welding technique in which the welding commences at the right hand edge of the welding job and proceeds towards the left. It is also called forward or forehand technique.

The blowpipe is held at an angle of $60^\circ - 70^\circ$ with the welding line. The filler rod is held at an angle of $30^\circ - 40^\circ$ with the welding line. The

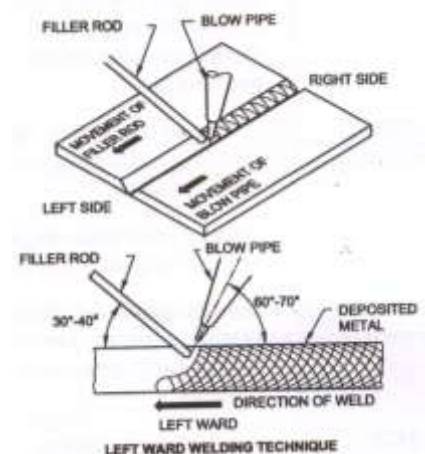

welding blowpipe follows the filler rod. The welding flame is directed away from the deposited weld metal.

The blowpipe is given a circular or side-to-side motion to obtain even fusion on each side of the joint. The filler rod is added in the (weld) molten pool by a piston like motion and not melted off by the flame itself.

If the flame is used to melt the filler rod itself into the pool, the temperature of the molten pool will be reduced and consequently good fusion cannot be obtained.

Edge preparation for leftward technique

- For fillet joints square edge preparation is done.
- For butt joints the edges are prepared as shown in figure given below.

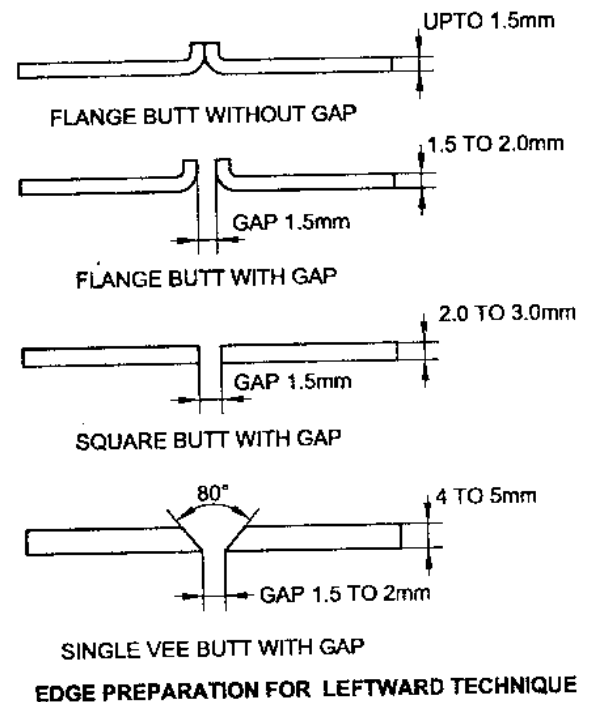

The table given below shows the details for welding mild steel by leftward technique (for butt joint)

metal thickness in mm	C.C.M.S. filler rod diameter in mm	Blow pipe nozzle size	edge preparation	root gap in mm	flux to be used
0.8	1.6	1	flange	Nil	for gas welding of mild steel no flux is required to be used
1.6 to 2.0	1.6	3	square	2	
2.5	2	5	square	2	
3.15	2.5	7	square	3	
4.0	3.15	7	80°Vee	3	
5.0	3.15	13	80°Vee	3	

For fillet joints one size larger nozzle is to be used.

Above 5.0 mm thickness, the rightward technique should be used.

Application - This technique is used for the welding of:

- Mild steel upto 5mm thickness
- All metals both ferrous and non-ferrous

3.8.2 Rightward Welding Technique

It is an oxy-acetylene gas welding technique, in which the welding is begun at the left hand edge of the welding job and it proceeds towards the right.

This technique was developed to assist the production work on thick steel plates (**above 5mm**) so as to produce economic welds of good quality. It is also called **backward** or **backhand** technique.

The blowpipe is held at an angle of 40° - 50° with the welding line. The filler rod is held at an angle of 30° - 40° with the welding line. The filler rod follows the welding blowpipe. The welding flame is directed towards the deposited weld metals.

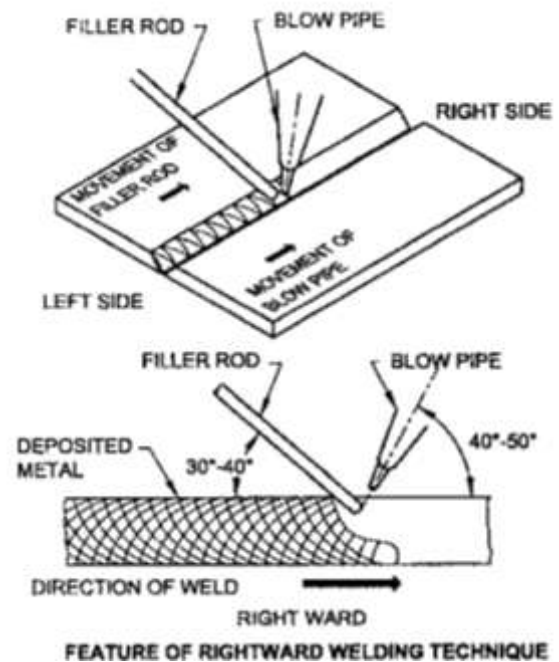

The filler rod is given a rotational or circular loop motion in the forward direction. The blowpipe moves back in a straight line steadily towards the right. This technique generates more heat for fusion, which makes it economical for thick steel plate welding.

Edge preparation for rightward technique

For butt joints the edges are prepared as shown in figure:

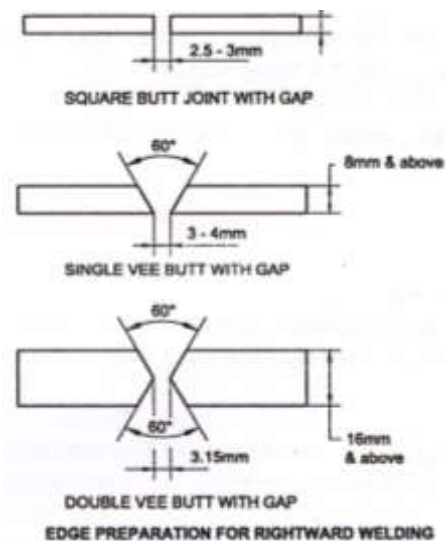

The table given below gives the details for welding mild steel by rightward technique for butt joint:

Metal thickness in mm	C.C.M.S filler rod diameter in mm	Blow pipe nozzle size	Edge preparation	root gas in mm	flux to be used
5	3.15	10	square	2.5	for gas welding of mild steel no flux is required to be used
6.3	4.0	13	square	3.0	
8	5.0	18	60°Vee	3.0	
10 to 16	6.3	18	60°Vee	4.0	
above 16	6.3	25	60° double Vee	3.0	

Application:

This technique is used for the welding of steel above **5mm** thickness and 'LINDE' welding process of steel pipes.

Advantages:

Less cost per length run of the weld due to less bevel angle, less filler rod being used and increased speed. Welds are made much faster.

3.9 WELDING OF LOW CARBON STEEL AND MEDIUM CARBON STEEL

A plain carbon steel is one in which carbon is the only alloying element. The amount of carbon in the steel controls its hardness, strength and ductility. The higher the carbon content, lesser the ductility of the steel.

Carbon steels are classified accordingly to the percentage of carbon they contain. They are referred to as low, medium and high carbon steels.

3.9.1 Low Carbon Steels

Steels with a carbon range of **0.05 to 0.30** percent are called low carbon steel or mild steel. Steels in this class are tough, ductile and easily machineable and quite easy to weld.

Welding technique: Up to 6 mm, leftward technique is a suitable one. Above 6 mm rightward technique is preferable.

Type of flame: Neutral flame to be used.

Application of flux: No flux is required.

After treatment: Most of them do not respond to any heat treatment process. Therefore except cleaning no post-heat treatment is required.

3.9.2 Medium Carbon Steel

These steels have a carbon range from **0.30 to 0.6** percent. They are strong and hard but can not be welded as easily as low carbon steels due to the higher carbon content. They can be heat treated. It needs greater care to prevent formation of cracks around the weld area, or gas pockets in the bead, all of which weaken the weld.

Welding procedure: Most medium carbon steels can be welded in the same way as mild steel successfully without too much difficulty but the metal should be preheated slightly to 160°C to 320°C (to dull red heat). After completion of welding, the metal requires post-heating to the same preheating temperature and allowed to cool slowly.

After cooling the weld is to be cleaned and inspected for surface defects and alignment.

The plate edge preparation depends on the thickness of the material to be welded.

3.9.3 High Carbon Steels

These steels have a carbon range from **0.6 to 1.2** percent. This type of steel is not weldable by gas welding process because it is difficult to avoid cracking of base metal and the weld.

CHAPTER 4

OXY-ACETYLENE GAS CUTTING

4.1 INTRODUCTION

The most common method of cutting mild steel is by an oxy-acetylene cutting process. With an oxy-acetylene cutting torch, the cutting (oxidation) can be confined to a narrow strip and with little effect of heat on the adjoining metal. The cut appears like a saw cut on a wooden plank. The method can be successfully used to cut ferrous metals i.e. mild steel.

Non-ferrous metals and their alloys **cannot be cut** by this process.

4.2 PRINCIPLE OF GAS CUTTING

When a ferrous metal is heated to red hot condition and then exposed to pure oxygen, a chemical reaction takes place between the heated metal and oxygen. Due to this oxidation reaction, a large amount of heat is produced and cutting action takes place.

In oxy-acetylene cutting the combination of red hot metal and pure oxygen causes rapid burning and iron is changed into iron oxide (oxidation). By this continuous process of oxidation the metal can be cut through very rapidly. The iron oxide is less in weight than the base metal.

The iron oxide in molten condition is also called **slag**. So the jet of oxygen coming from the cutting torch will blow the molten slag away from the metal making a gap called "**Kerf**".

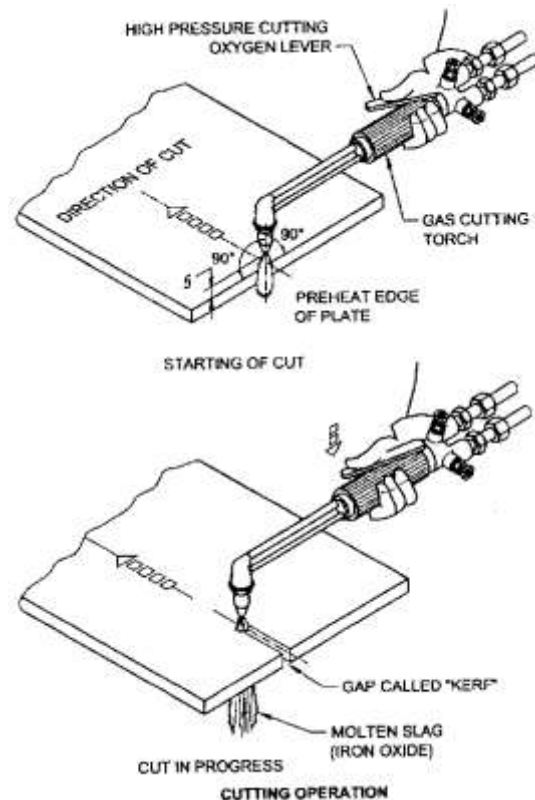

4.2.1 Cutting Operation

There are two operations in oxy-acetylene gas cutting. A preheating flame is directed on the metal to be cut and raises it to bright red hot or ignition point (900°C app.) Then a stream of high pressure pure oxygen is directed on to the hot metal which oxidizes and cuts the metal. The two operations are done simultaneously with a single torch.

The torch is moved at a proper travel speed to produce a smooth cut. The removal of oxide particles from the line of cut is automatic by means of the force of oxygen jet during the progress of cut.

4.2.2 Application of Cutting Torch

Oxy-acetylene cutting torch is used to cut mild steel plates above 4mm thickness. The M.S. plate can be cut to its full length in straight line either parallel to the edge or at any angle to the edge of a plate. Beveling the edges of a plate to any required angle can also be done by tilting the torch. Circles and any other curved profile can also be cut using the cutting torch by using a suitable guide or template.

4.3 OXY-ACETYLENE CUTTING EQUIPMENT

The oxy-acetylene cutting equipment is similar to the welding equipment, except that instead of using a welding blowpipe, a cutting blowpipe is used.

- Acetylene gas cylinder
- Oxygen gas cylinder
- Acetylene gas regulator
- Oxygen gas regulator (Heavy cutting requires higher pressure oxygen regulator)
- Rubber hose-pipes for acetylene and oxygen
- Cutting blowpipe

4.3.1 Cutting Torch

The cutting torch differs from the regular welding blowpipe in most cases. It has an additional lever for the control of the cutting oxygen used to cut the metal. The torch has the oxygen and acetylene control valves to control the oxygen and acetylene gases while preheating the metal.

The cutting tip is made with an ORIFICE in the centre surrounding by five smaller holes. The centre opening permits the flow of the cutting oxygen and the smaller holes are for the preheating flame. Usually different tip sizes are provided for cutting metals of different thicknesses.

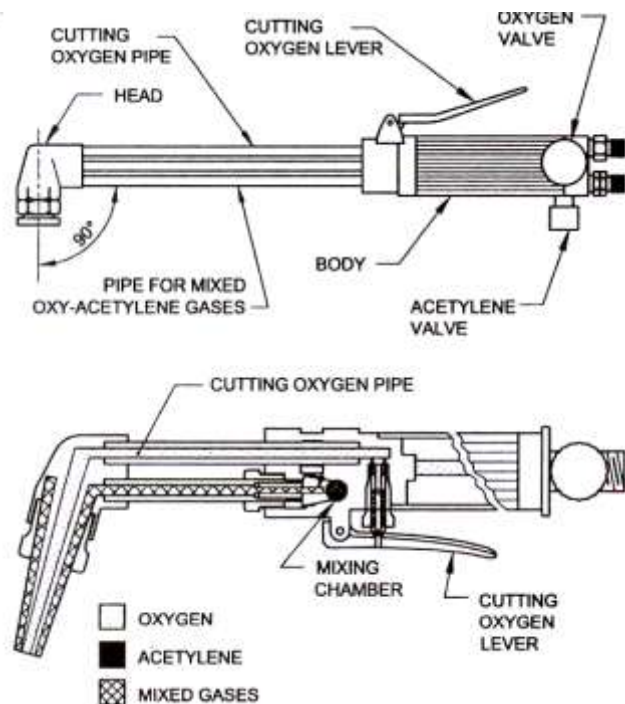

4.3.2 Difference Between Cutting Torch (blowpipe) and Welding Blowpipe

- A cutting blowpipe has two control valves (oxygen and acetylene) to control the preheating flame and one lever type control valve to control the high pressure pure oxygen for making the cut.
- A welding blowpipe has only two control valves to control the heating flame.
- The nozzle of the cutting blowpipe has one hole in the centre for cutting oxygen and a number of holes around the circle for the preheating flame.

- The nozzle of welding blowpipe has only one hole in the centre for the heating flame.
- The angle of the cutting nozzle with the body is 60°.
- The angle of the welding nozzle with the neck is 120°.
- The cutting nozzle size is given by the diameter of the cutting oxygen orifice in mm.
- The welding nozzle size is given by the volume of oxy-acetylene mixed gases coming out of the nozzle in cubic meter per hour.

4.3.3 Care and Maintenance

- The high pressure cutting oxygen lever should be operated only for gas cutting purpose.
- Care should be taken while fitting the nozzle with the torch to avoid wrong thread.
- Dip the torch after each cutting operation in water to cool the nozzle.
- To remove any slag particles or dirt from the nozzle orifice use the correct size nozzle cleaner.
- Use an emery paper if the nozzle tip is damaged to make it sharp and to be at 90° with the nozzle axis.

4.3.4 Problems with Cutting Torch

Trouble	Part to be checked	Method	remedy	When to be checked
gas leakage	hose joint	soap water or water	tighten further or replace	at the beginning of the work.
	valve & regulator	soap water or water	replace the torch	at the beginning of the work.
	cutting tip attaching part	soap water or water	tighten further or replace	at the beginning of the work.
suction of acetylene	injector	plug the fuel gas hose mouth with your finger.	replace	periodical check for the low pressure torch.
preheating flame shape		neutral flame by visual inspection	Clean or replace.	at the beginning of the work or at random
cutting oxygen flow		visible gas flow by visual inspection	clean or replace	at the beginning of the work or at random.

CHAPTER 5

FAULTS AND DEFECTS IN GAS & ARC WELDING

5.1 WELD DEFECTS & TYPES

A defect or fault is one which does not allow the finished joint to withstand or carry the required load.

Weld defects may be considered under two heads.

- External defects
- Internal defects

The defects which can be seen with bare eyes or with a lens on the top of the weld bead, or on the base metal surface or on the root side of the joint are called external defects.

Those defects, which are hidden inside the weld bead or inside the base metal surface and which cannot be seen with bare eyes or lens are called internal defects.

Some of the weld defects are external defects, some are internal defects and some defects like crack, blow hole and porosity, slag inclusion, lack of root penetration in fillet joints, etc. will occur both as external and internal defects.

5.1.1 External Defects

1. Undercut
2. Cracks
3. Blow hole and porosity
4. Slag inclusions
5. Edge of plate melted off
6. Excessive convexity/ oversized weld/ excessive reinforcement
7. Excessive concavity/ insufficient throat thickness/ insufficient fill
8. Incomplete root penetration/ lack of penetration
9. Excessive root penetration
10. Overlap
11. Mismatch
12. Uneven/ irregular bead appearance
13. Spatters

5.1.2 Internal Defects

1. Cracks
2. Blow hole and porosity
3. Slag inclusions
4. Lack of fusion
5. Lack of root penetration
6. Internal stresses or locked-up stresses or restrained joint.

5.2 TYPES OF FAULTS IN GAS WELDING

A fault is an imperfection in the weld which may result in failure of the welded joint while in service. The following faults occur commonly in gas welding:

Undercut

A groove or channel formed along the toe of the weld on one side or on both sides.

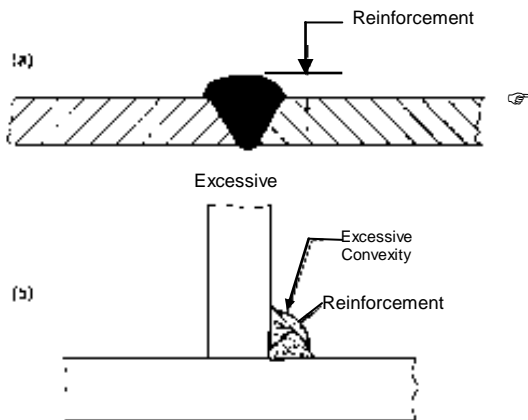
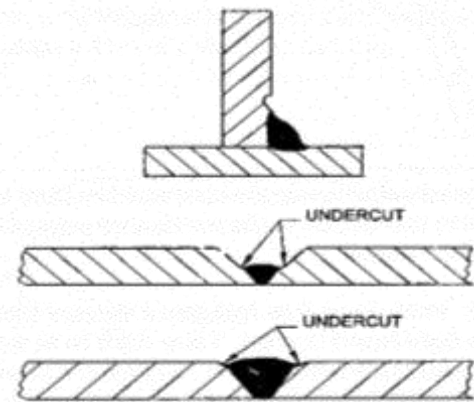

Excessive convexity

Too much weld metal added to the joint so that there is excessive weld reinforcement.

Overlap

Metal flowing into the surface of the base metal without fusing it.

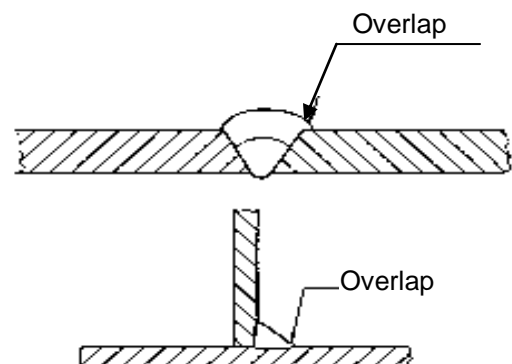

Excessive penetration

Depth of fusion at the root of the grooved joint is more than the required amount.

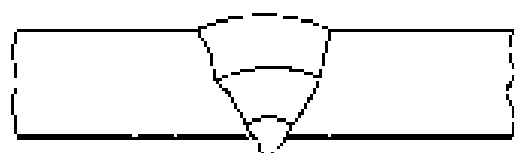

Excess Weld Metal at the Root

Lack of penetration

Required amount of penetration is not achieved i.e. fusion does not take place upto the root of the weld.

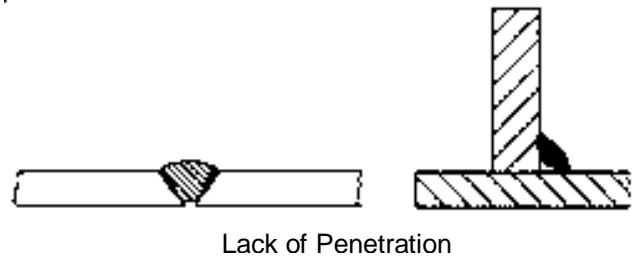

Lack of fusion

If there is no melting of the edges of the base metal at the root face or on the side face or between the weld runs, then it is called lack of fusion.

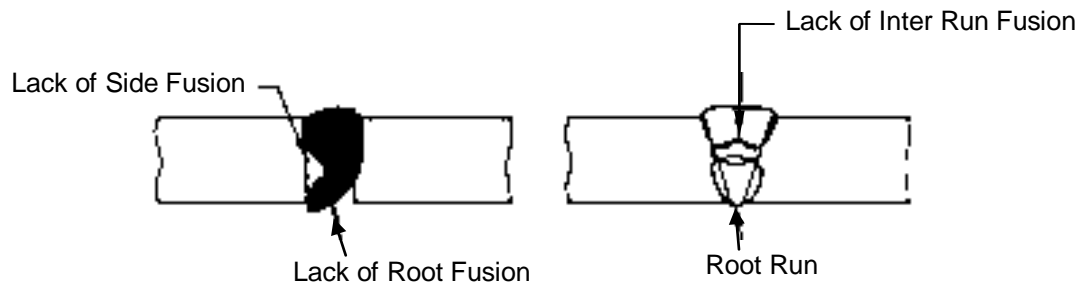

Porosity

Number of pinholes formed on the surface of the deposited metal.

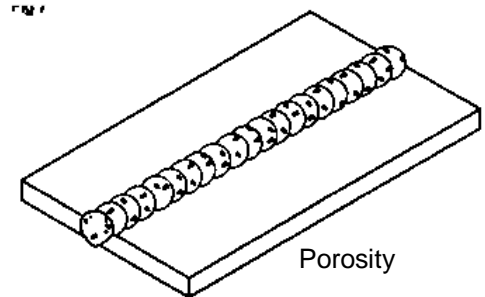

Blow-holes

These are similar to pinholes but have a greater diameter.

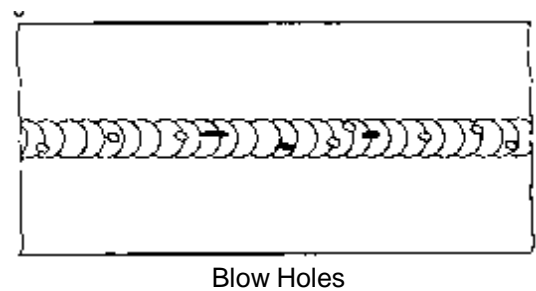

Cracks

A discontinuity in the base metal or weld metal or both.

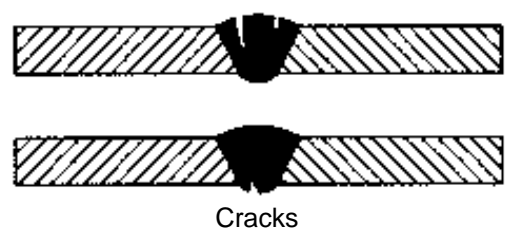



Unfilled crater

A depression formed at the end of the weld.

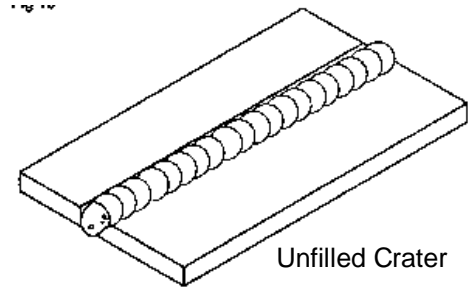

Excessive concavity/ insufficient throat thickness

Enough weld metal is not added to the joint so that there is insufficient throat thickness.

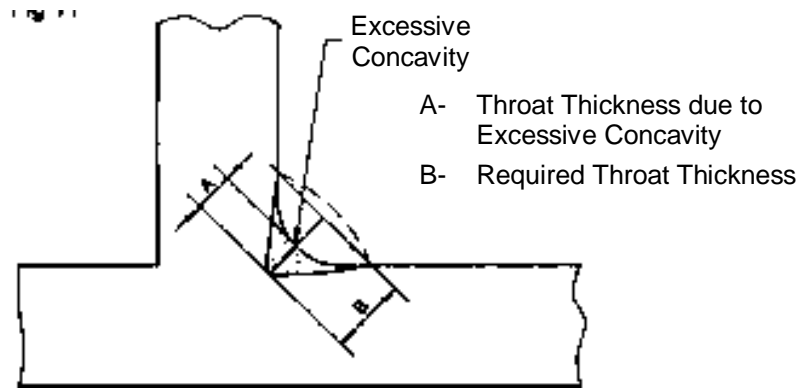

Burn through

A collapse of the molten pool due to excessive penetration, resulting in a hole in the weld run.

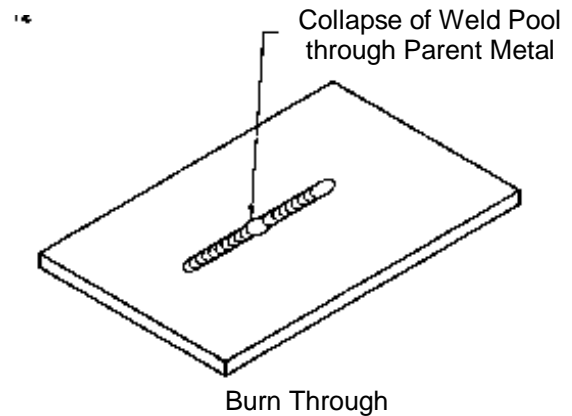

5.3 GAS WELD DEFECTS – POSSIBLE CAUSES AND REMEDIES

Sr.	Defect	Possible causes	Appropriate remedies
1.	Fillet weld with insufficient throat thickness.	Incorrect angle of filler rod and blowpipe.	Maintain filler rod and blowpipe at the appropriate angles.
2.	Excessive concavity in butt weld profile.	Excess heat build-up with too fast a speed of travel or filler rod too small.	Use the appropriate size nozzle and filler rod with the correct speed of travel.
3.	Excessive penetration. Excess fusion of root edges.	Angle of slope of nozzle too large. Insufficient forward heat. Flame size and/or velocity too high. Filler rod too large or too small. Speed of travel too slow.	Maintain the nozzle at the correct speed of travel. Select correct nozzle size. Regulate flame velocity correctly. Use correct size of filler rod. Travel at the correct speed.
4.	Burn through.	Excessive penetration has produced local collapse of weld pool resulting in a hole in the root run.	Maintain blowpipe at the correct angles. Check nozzle size, filler rod size. Travel at the correct speed.
5.	Undercut along vertical member of fillet welded tee joint.	Incorrect angle of tilt used in blowpipe manipulation.	Maintain blowpipe at the correct angle.
6.	Undercut in both sides of weld face in butt joint.	Wrong blowpipe manipulation, incorrect distance from plate surface, excessive lateral movement. Use of too large a nozzle.	Use correct nozzle size, speed of travel and lateral blowpipe manipulation.
7.	Incomplete root penetration in butt joint (single Vee or double Vee)	Incorrect set up and joint preparation. Use of unsuitable procedure and/or welding technique.	Ensure joint preparation and set up are correct. Appropriate procedure and/ or welding technique must be used.
8.	Incomplete root penetration in close square Tee joint.	Incorrect set up and joint preparation. Use of unsuitable procedure and/or welding technique.	Ensure joint preparation and set up are correct. Appropriate procedure and/ or welding technique must be used.

Sr.	Defect	Possible causes	Appropriate remedies
9.	Lack of root penetration	Incorrect joint preparation and set up. Gap too small. Vee preparation too narrow. Root edges touching.	Prepare and set up the joint correctly.
10.	Lack of fusion on root and side faces of double Vee butt joint.	Incorrect set up and joint preparation. Use of unsuitable welding technique.	Ensure the use of correct joint preparation, set up and welding technique.
11.	Lack of inter-run fusion	Angles of nozzle and blowpipe manipulation incorrect.	Correct the angles of slope and tilt. Use blowpipe manipulation to control uniform heat built-up.
12.	Weld face cracks in butt and fillet welds.	Use of incorrect welding procedure. Unbalanced expansion and contraction stresses. Presence of impurities. Undesirable chilling effects. Use of incorrect filler rod.	Use correct procedure and filler rod. Ensure uniform heating and cooling. Check suitability and surface preparation of material before welding. Avoid draughts and use appropriate heat treatment.
13.	Surface porosity and gaseous intrusions.	Use of incorrect filler rod and technique. Failure to clean surfaces before welding. Absorption of gases due to incorrectly stored fluxes, unclean filler rod. Atmospheric contamination.	Clean plate surfaces. Use correct filler rod and technique. Make sure the flame setting is correct to avoid gas contamination.
14.	Crater at end of weld run. Small cracks may be present.	Neglect to change the angle of blowpipe, speed of travel or increase the rate of weld metal deposition as welding is completed at the end of the seam.	Reduce the angle of the blowpipe progressively with speed of travel to lower the heat input and deposit, and deposit sufficient metal to maintain the toe of the weld pool at the correct level until it has completely solidified.

5.4 ARC WELD DEFECTS – POSSIBLE CAUSES AND REMEDIES

➤ UNDERCUT

A groove or channel formed in the parent metal at the toe of the weld.

Causes

- Current too high
- Use of a very short arc length
- Welding speed too fast
- Overheating of job due to continuous welding
- Faulty electrode manipulation.
- Wrong electrode angle.

Remedies

a. Preventive action

Ensure

- Proper current is set
- Correct welding speed is used
- Correct arc length is used
- Correct manipulation of electrode is followed.

b. Corrective actions

- Deposit A thin stringer bead at the top of the weld using a 2mm ϕ electrode to fill up the undercut.

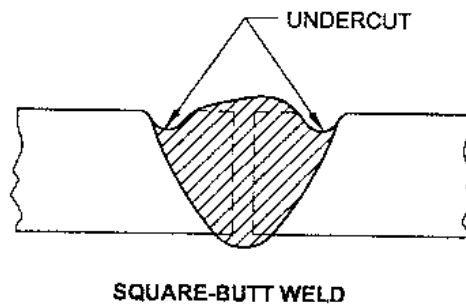
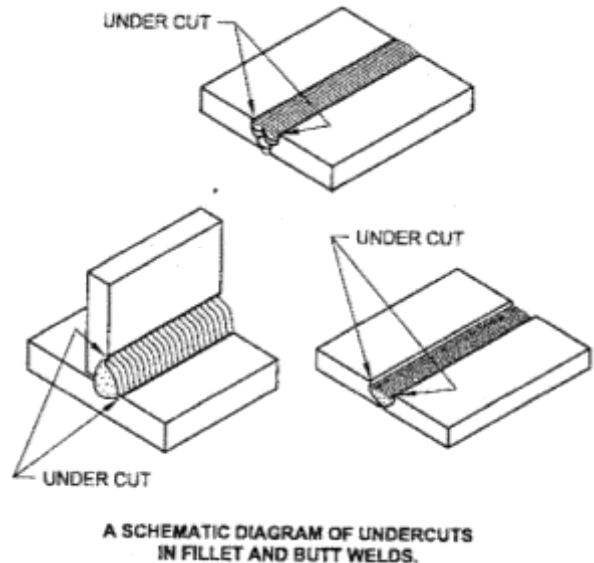
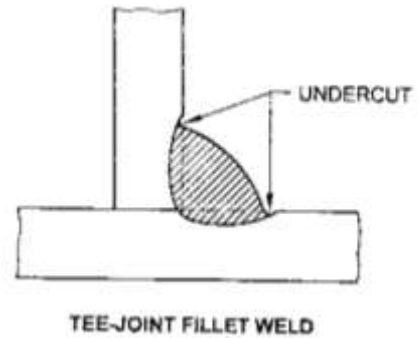

➤ OVERLAP

An overlap occurs when the molten metal from the electrode flows over the parent metal surface without fusing into it.

Causes

- Low current
- Slow arc travel speed.
- Long arc
- Too large a diameter electrode
- Use of wrist movement for electrode weaving instead of arm movement.

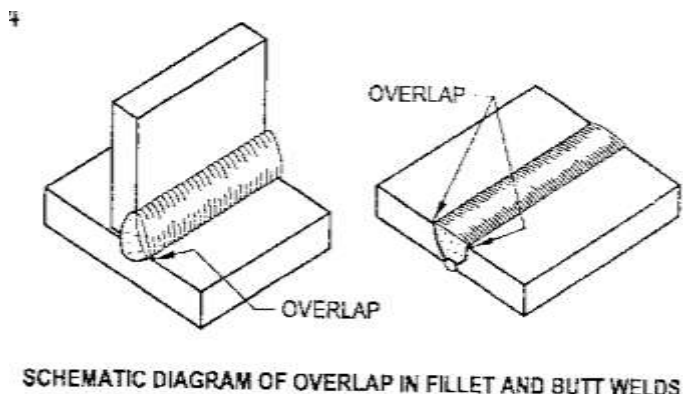

Remedies

(a) Preventive actions

- Correct current setting
- Correct arc travel speed
- Correct arc length
- Correct diameter electrode as per metal thickness.
- Proper manipulation of electrode

(b) Corrective actions

- Remove the overlap by grinding without an undercut.

➤ **BLOWHOLE AND POROSITY**

Blow hole or gas pocket is a large diameter hole inside a bead or on the surface of the weld caused by gas entrapment. Porosity is a group of fine holes on the surface of the weld caused by gas entrapment.

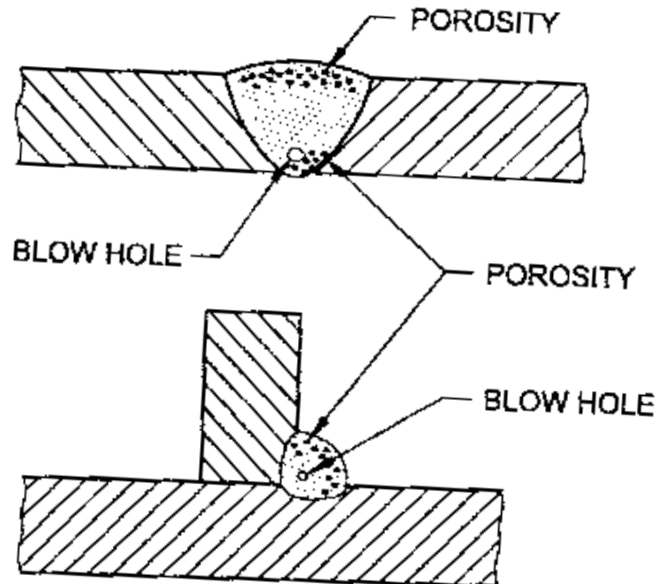

Causes

- Presence of contaminants/ impurities on the job surface or on electrode flux.
- Presence of high sulphur in the job or electrode materials.
- Trapped moisture between joining surfaces.
- Fast freezing of weld metal.
- Improper cleaning of the edges.

Remedies

a. Preventive actions

- Remove oil, grease, rust, paint, moisture, etc. from the surface.
- Use fresh and dried electrodes.
- Use good flux-coated electrodes.
- Avoid long arcs.

b. *Corrective action*

If the blowhole or porosity is inside the weld then gouge the area and reweld. If it is on the surface then grind it and reweld.

➤ **SPATTER**

Small metal particles which are thrown out of the arc during welding along the weld and adhering to the base metal surface.

Causes

- Welding current too high.
- Wrong polarity (in DC).
- Use of long arc.
- Arc blow.
- Uneven flux coated electrode.

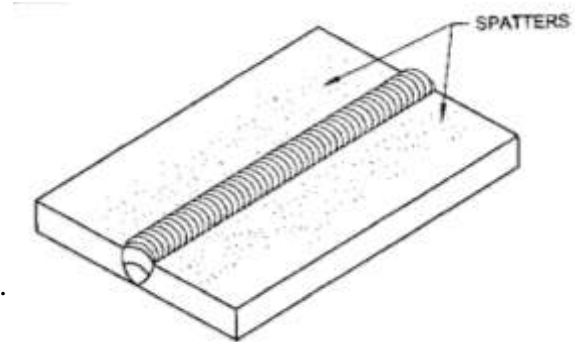

Remedies

(a) *Preventive actions*

- Use correct current
- Use correct polarity (DC)
- Use correct arc length
- Use good flux coated electrode

(b) *Corrective actions*

- Remove the spatters using a chipping hammer and wire brush.

➤ **EDGE OF PLATE MELTED OFF**

Edge of plate melted off defect takes place in lap and corner joints only. If there is excess melting of one of the plate edges resulting in insufficient throat thickness then it is called edge of plate melted off defect.

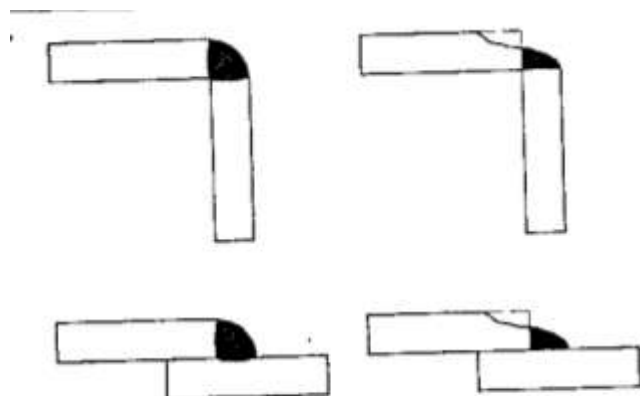

Causes

- Use of oversize electrode
- Use of excessive current.
- Wrong manipulation of the electrode i.e. excessive weaving of electrode.

Remedies**(a) Preventive action**

- Select correct size electrode
- Set correct current
- Ensure correct manipulation of electrode

(b) Corrective action

- Deposit additional weld metal to increase throat thickness.

➤ CRACK

A hairline separation exhibits in the root or middle or surface and inside of the weld metal or parent metal.

Causes

- Wrong selection of electrode.
- Presence of localized stress.
- A restrained joint
- Fast cooling
- Improper welding techniques/ sequence
- Poor ductility
- Absence of preheating and post-heating of the joint
- Excessive sulphur in base metal.

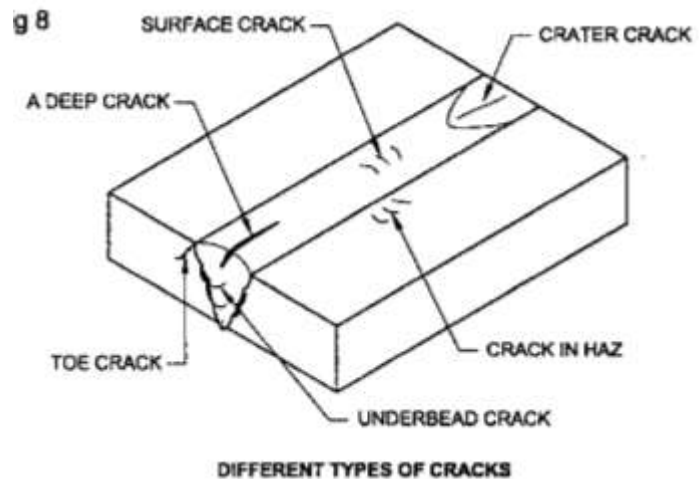
**Remedies****(a) Preventive actions**

- Preheat and post-heating to be done on copper, cast iron, medium and high carbon steels.
- Select a low hydrogen electrode
- Cool slowly
- Use fewer passes
- Use proper welding technique/ sequence.

(b) Corrective actions

- For all external cracks to a smaller depth, take a V groove using a diamond point chisel upto the depth of the crack and reweld (with preheating if necessary) using low hydrogen electrode. Cool the job slowly.
- For internal/ hidden cracks gouge upto the depth of the cracks and reweld (with preheating if necessary) using low hydrogen electrode. Cool the job slowly.

➤ **INCOMPLETE PENETRATION**

Failure of weld metal to reach and fuse the root of the joint.

Causes

- Edge preparation too narrow-less bevel angle.
- Welding speed too much.
- Key-hole not maintained during welding the root run of a grooved joint.
- Less current
- Use of larger dia. Electrode.
- Inadequate cleaning or gouging before depositing sealing run.
- Wrong angle of electrode.
- Insufficient root gap.

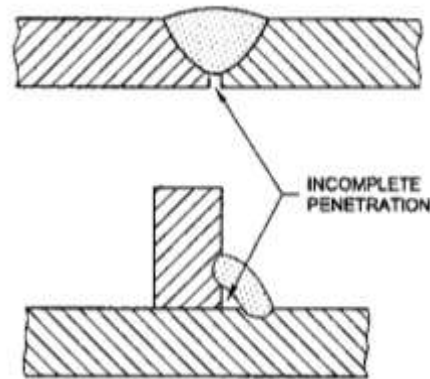

Remedies

(a) Preventive actions

- Correct edge preparation is required.
- Ensure correct angle of bevel and required root gap.
- Use correct size of electrode
- Correct welding speed is required.
- Maintain a key-hole throughout the root run.
- Correct current setting is required.

(b) Corrective actions

- For butt welds and open corner welds gouge the root of the joint and deposit the root run from the bottomside of the joint. For a Tee & lap fillet welds blow of the full weld deposit and reweld the joint.

➤ **SLAG INCLUSION**

Slag or other non-metallic foreign materials entrapped in a weld.

Causes

- Incorrect edge preparation
- Use of damaged flux coated electrode due to long storage.
- Excessive current
- Long arc length
- Improper welding technique.
- Inadequate cleaning of each run in multi-run welding.

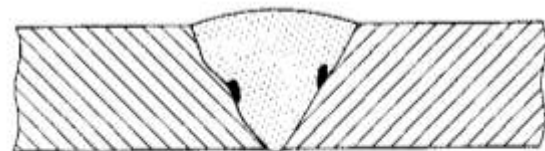

SLAG INCLUSION IN BUTT WELD

Remedies**(a) Preventive actions**

- Use correct joint preparation.
- Use correct type of flux coated electrode.
- Use correct arc length.
- Use correct arc welding technique.
- Ensure thorough cleaning of each run in multi-run welding.

(b) Corrective actions

- For external/ surface slag inclusion remove them using a diamond point chisel or by grinding and reweld that area. For internal slag inclusions use gouging upto the depth of the defect and reweld.

ANNEXURE - I**CLASSIFICATION OF ELECTRODES AS PER THEIR APPLICATION ALONG WITH IS/ AWS SPECIFICATION AND CODING THEREOF (Ref: IRS:M28/2012)**

S.N.	IRS CLASS	USE	IS/AWS SPEC.	IS/AWS CODE
1.	A-1	Fabrication of component meant for static application made of steels to IS: 2062-11, Gr E250 Quality A, IS: 1875-04 Class 1 & 1A or equivalent. Suitable for joining steel sheets to IS:513-98, IS: 1079-94 & Gr. Fe 330 to IS:5986-02 or equivalent and for repair welding of cast steels to IS: 1030-98 Gr.-200-400W. This electrode can also be used for welding where strength requirement is not specified.	IS: 814-04	ER 4112 (Medium coated)
2.	A-2	Fabrication of component meant for semi-dynamic application such as bridges etc., made of steel to IS: 2062-11 Gr. E250 Quality BR&B0, IS: 1875-04 Class I & IA or similar. The weld deposit shall be of radiographic quality.	IS: 814-04	ER 4211X (Medium coated)
3.	A-3	Fabrication of component meant for highly dynamic application made of steels to IS: 2062-11 Gr.E 250 quality C or for other applications where low temperature impact property is required. The weld deposit shall be of radiographic quality.	IS: 814-04	EB 5326H2X (Heavy coated)
4.	A-4	Application same as A3 above with high deposition efficiency.	IS: 814-04	EB 5326H2JX (Heavy coated)
5.	A-5	For pipe welding or other applications where high penetration of arc is needed.	IS: 814-04	EC 4316X (Medium coated)
6.	B-1	Fabrication of component made of steels to IS:2062-11 Gr.E300 & E350 all quality, IS:2002-01 Gr.1&2, IS: 1875-04 Class 2, 2A and 3 or similar. Also suitable for repair welding of cast steels to IS: 1030-98 Gr.230-450W. The weld deposit shall be radiographic quality. Also for joining of stainless steels type 3 Cr12, IRS M-44 or its equivalent with mild steel/ low alloyed steel/ Corten steel.	IS: 814-04	EB5426H3X (Heavy coated)
7.	B-2	Application same as B-1 above with high deposition efficiency	IS: 814-04	EB5426H3JX (heavy coated)
8.	B-3	Fabrication of components made of steel to ASTM 516 GR. 70 or equivalent where low temperature (at-46°C) impact properties are required. The weld deposit shall be of radiographic quality.	IS: 1395-03	E55BC126 (heavy coated)

S.N.	IRS CLASS	USE	IS/AWS SPEC.	IS/AWS CODE
9.	B-4	Application same as B-3 above with high deposition efficiency.	IS: 1395-03	E55BC126J (heavy coated)
10.	C-1	Fabrication of components made of steel to IS: 2062-11 Gr.E410, 450, IS: 2002-01 GR.3, IS: 1875-04 class 3A or similar. The weld deposit shall be of radiographic quality.	IS: 1395-03	E63BD126 (heavy coated)
11.	C-2	Application same as C1 above with high deposition efficiency.	IS: 1395-03	E63BD126J (heavy coated)
12.	D	For joining weathering steels conforming to IRS M-41 or M-42 with same steel or steels to IS: 2062-11, IS: 2002-01, IS: 1875-92 as mentioned above. This can also be used for combination joint of IRS M-44 & IRS M-41 and IRS M-41 & M-42. The weld deposit shall be of radiographic quality.	AWS A5.5	E8018W2 (heavy coated)
13.	E-1	For fabrication & repairing of Buckles, Gear cases, Protector Tubes, Door Patches, Side Panels, End Wall Patches etc. of rolling stock & locomotives. The electrodes shall be low heat input type with 350 mm length.	IS: 814-04	ER4211X (medium coated)
14.	E-2	For repair welding of bogies, both cast & fabricated. The electrodes shall be low heat input type with 350mm length.	IS: 1395-03	E55BG1Ni26 (heavy coated)
15.	F	For reclamation of cast iron with non-machineable deposit.	IS: 5511-03	EFe B26 (medium coated)
16.	G	For welding of cast iron with machinable deposit (Ni-Fe type core wire). Also suitable for joining of cast iron to other ferrous & non-ferrous materials.	IS: 5511-03	ENiFeG16 (Medium coated)
17.	H3	For resurfacing of fabricated medium-Mn steel or cast Mn. Steel crossings to withstand traffic density of 15 GMT minimum.	--	--
18.	H3A	Application same as H3 above to withstand traffic density of 25 GMT minimum.	--	--
19.	H3B	Application same as H3 above to withstand traffic density of 35 GMT minimum.	--	--
20.	H3C	Application same as H3 above to withstand traffic density of 50 GMT minimum.	--	--
21.	H4A	For non-machinable hard facing of ferrous items with hardness range of 55-62 Rc.	IS: 7303-03	EFe-IC314 (heavy coated)
22.	H4B	For machinable hard facing of ferrous items with hardness range of 30-40 HRC like reclamation of equalizing beam etc.	IS: 7303-03	EFe-B314 (heavy coated)
23.	K	For welding of copper, bronze and other copper alloys including gun-metal	IS:8666-03	ECuSn-A (medium coated)

S.N.	IRS CLASS	USE	IS/AWS SPEC.	IS/AWS CODE
24.	L	For welding of aluminium and aluminium alloys	AWS A5.3	AL-43 (Medium coated)
25.	M1	For fabrication of stainless steels type 18% Cr 8% Ni type or its equivalent.	IS: 5206-03	E19.9R26 (Heavy coated)
26.	M2	For fabrication of stainless steels type 3Cr12, IRS M-44 or its equivalent. Also suitable for fabrication of 18% Cr 8% Ni stainless steels with low carbon.	IS: 5206-03	E19.9LR26 (Heavy coated)
27.	M3	For fabrication of stainless steels type 316 or its equivalent.	IS: 5206-03	E19.12.2R26 (Heavy coated)
28.	M4	For fabrication of ferritic stainless steels type 3Cr12, IRS M-44 or its equivalent. Also suitable for joining dissimilar stainless steels as mentioned in M1, M2 and M3 or their equivalent. This is also suitable for joining M1, M2 and M3 type of stainless steels as mentioned above or their equivalent with mild steel or low alloyed steel. This can also be used for welding of heat resisting stainless steels 22% Cr 12% Ni type or its equivalent.	IS: 5206-03	E23.12LR26 (heavy coated)
29.	M5	For joining of manganese steel liners and other austenitic manganese steel components with steel casting to IS: 1030-98 Gr.230-450W/280-520W or to IS: 2062-11	IS: 5206-03	E18.8MnR26 (Heavy coated)
30.	M6	For repair welding of cracked gas inlet casting of diesel locomotives. These can also be used for other repair welding of stainless steels castings having higher percentage of carbon and for welding of high heat resisting stainless steels 25% Cr 20% Ni type or its equivalent.	IS: 5206-03	E25.20R26 (heavy coated)
31.	M7	For joining of cast ferrous alloy of similar composition, dissimilar metals such as carbon steels to stainless steels & welding of steels of unknown composition.	IS: 5206-03	E29.9R26 (Heavy coated)
32.	N-1	For cutting mild steels, low alloy steels, stainless steels, austenitic manganese steels, cast iron, cast steel & non-ferrous alloys such as nickel alloys, Al, Cu, bronzes etc.	--	--
33.	N-2	For gouging & piercing of steels and non-ferrous alloy as described in class N1.	--	--
34.	N-3	For gouging of mild steels, low alloy steels, stainless steels, austenitic manganese steels and cast iron & cast steel. The electrode shall be of copper coated graphitic type.	--	--

ANNEXURE - II**USAGE AND STORAGE OF ELECTRODES****Usage and Storage of Electrodes**

- Electrodes are costly, therefore, use and consume every bit of them.
- Do not discard STUB ENDS more than 40-50 mm length.
- Electrode coating can pick up moisture if exposed to atmosphere.

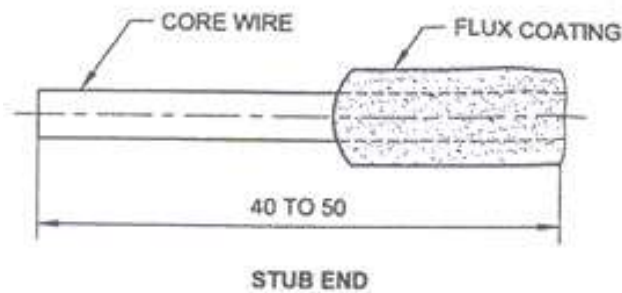

- Store and keep the electrodes (air tight) in a dry place.
- Heat the moisture affected/ prone electrodes in an electrode drying oven at 110-150°C for one hour before using.

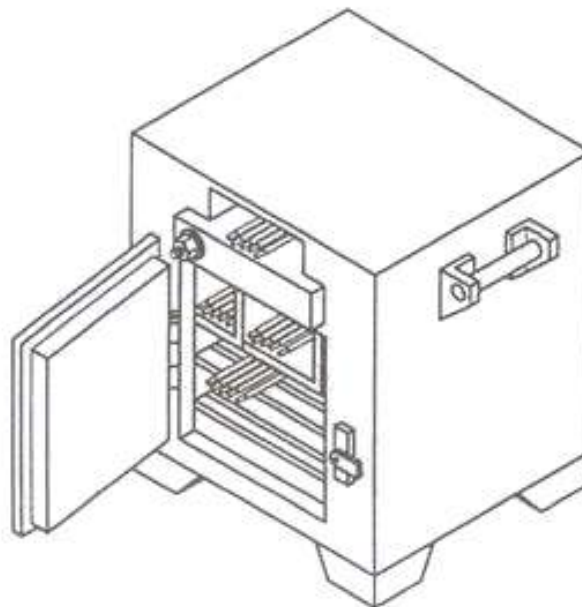
**ELECTRODE DRYING OVAN****Remember a Moisture Affected Electrode:**

- has rusty stub end
- has white powder appearance in coating
- produces porous weld.

Storage of Electrodes:

The efficiency of an electrode is affected if the covering becomes damp.

- Keep electrodes in unopened packets in a dry store.
- Place packages on a duckboard or pallet, not directly on the floor.
- Store so that air can circulate around and through the stack.
- Do not allow packages to be in contact with walls or other wet surfaces.
- The temperature of the store should be about 5°C higher than the outside shade temperature to prevent condensation of moisture.
- Free air circulation in the store is as important as heating. Avoid wide fluctuations in the store temperature.
- Where electrodes cannot be stored in ideal conditions place a moisture absorbent material (e.g. silica gel) inside each storage container.

Drying Electrodes: Water in electrode covering is a potential source of hydrogen in the deposited metal and thus may cause.

- Porosity in the weld
- Cracking in the weld

Indications of electrodes affected by moisture are:

- White layer on covering
- Swelling of covering during welding
- Dis-integration of covering during welding
- Excessive spatter
- Excessive rusting of the core wire.

Electrode affected by moisture may be dried before use by putting them in a controlled drying oven for approximately one hour at a temperature around 110-150°C. This should not be done without reference to the conditions laid down by the manufacturer. It is important that hydrogen controlled electrodes are stored in dry, heated conditions at all times.

For further details, refer the manufacturer's instructions and follow them.

ANNEXURE - III**GUNA BAR TECHNIQUE FOR REPAIRING OF CRACKED CAST STEEL BOGIE FRAMES**

EWAC Alloys Limited Mumbai (a subsidiary of L&T Limited) has developed special technique for certain situations/service conditions of cast steel.

Casto-Guna Technique

This process involves welding the crack fully or partially and then reinforcing Guna bars across the length of the crack.

Casto-guna process is used in two different areas:

- 1) Where the crack is very deep, making a U groove preparation up to depth of the crack in root will enable considerable amount of welding material. This will increase the cost of repair and also the welding stresses. In such situation, only the 2/3rd of the crack is filled up and reinforcing bars are placed across to compensate for the reduced strength due to 1/3 un-welded area at bottom.
- 2) This guna bar technique is also adopted where full welding is done but additional strength is required.



- The first step in casto-guna process is to weld up to the depth of the crack. If practically not possible, then welding to whatever depth possible should be done using the normal techniques.
- When welding is done only part of the depth, an AISI 304 SS tube of 2 or 3 mm wall thickness and about 15 – 20 mm diameter, must be placed along the length of the crack to prevent propagation of the crack while welding, the tube must be welded both the side by using CPEM 021 only.
- Guna bars are then welded using EWAC 660 NH/CPEM 021
- The guna bars normally selected are steels of EN 8 or EN 24 type annealed and tempered, both these have good strength and are readily available.
- The length of the bar should be such that it overlaps the weld bead by at list 75 mm on both sides, the bar should be cylindrical only.
- Cylindrical bars are preferred and diameter could be about 20 -25 mm

- The bars are to be placed in a staggered fashion with 2/3 rd of the length on one side and 1/3rd on the other side of the crack.
- Guna bars serves to compensate for loss of strength due to unwelded depth.
- Selection of number of bars for such purposes has to be made as per the following formula

Total strength of bars welded area:

No. of bars x yield strength of bar x cross sectional area of bar = tensile strength of cast steel x relevant cross sectional area of cast steel

- Yield strength is considered so as not to allow any plastic deformation of guna bars and thereby an additional safety margin is provided to the joint. If further strength to be improved, filling of inter bar spacing provides additional strength.
- If crack is not in a single plain and in such cases guna bars will have to be bent to the profile before placing for final welding. This technique can be adopted for other metals like cast iron, copper alloys etc. The changes of welding consumable and guna bar are essential.

ANNEXURE - IV

Welding Symbols

Welding symbols are used on drawings to indicate the type and specifications of the weld. The figure shows the *American Welding Society (AWS)* standard welding symbol. The most important features of the welding symbol are illustrated below:

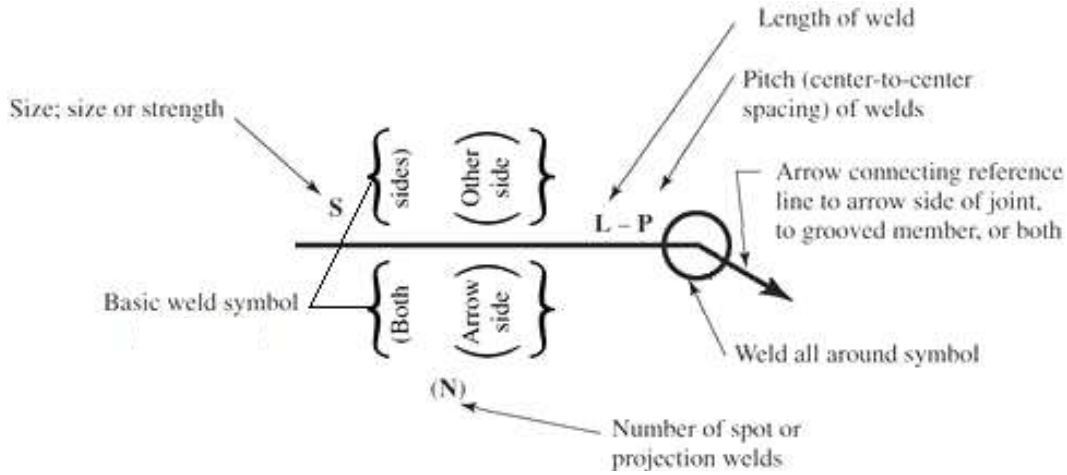

The table shows the *Basic weld symbol* for the different types of welds.

Type of weld							
Bead	Fillet	Plug or slot	Groove				
			Square	V	Bevel	U	J

The figures below show some examples for the use of welding symbols.

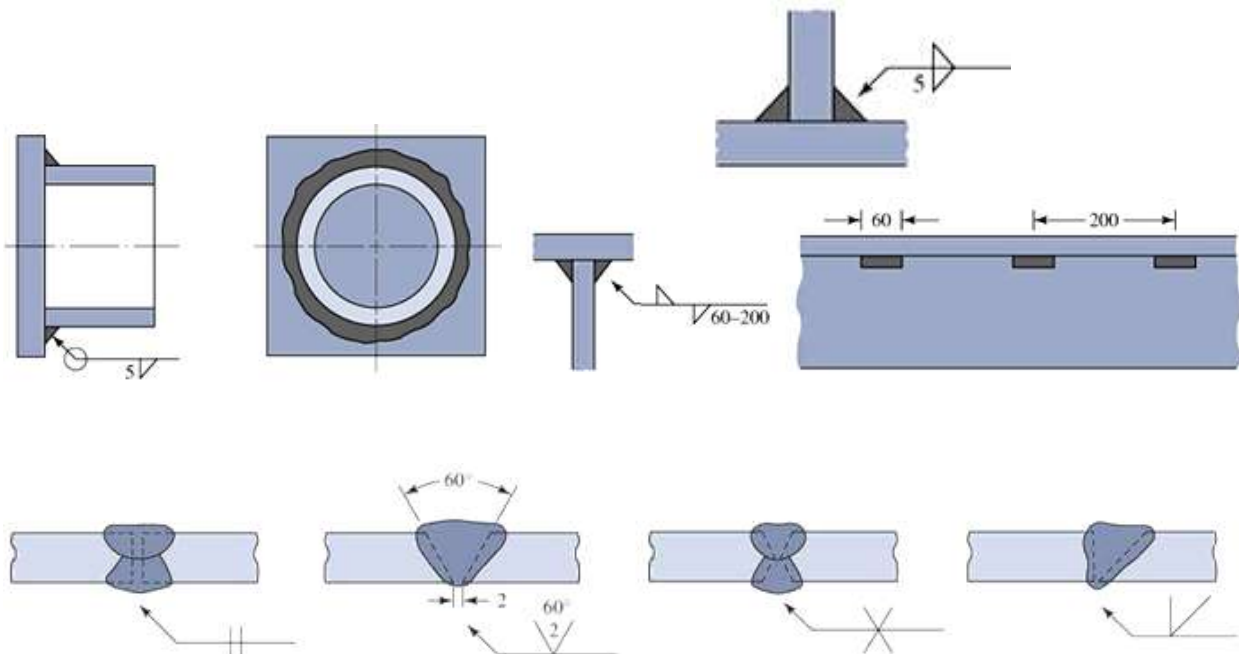

REFERENCES

1. Literature provided by EWAC Alloys Limited Mumbai (a subsidiary of L&T Limited).
2. Book on Welding Engineering Technology by Dr.R.S.Parmar.
3. Book on Welder Trade Theory published by National Instructional Media Institute, Chennai (under Directorate General of Employment and Training, Ministry of Labour and Employment, Govt. of India).
4. Book “Welding notes for Artisans” issued by Basic Training Centre (C&W), Nagpur Division, Central Railway.
5. Suggestions received during seminar held on 14th November, 2011 at CAMTECH Gwalior on “Welding process for good quality weld”.
6. Information available on Internet.

OUR OBJECTIVE

To upgrade maintenance technologies and methodologies and achieve improvement in productivity, performance of all Railway assets and manpower which inter-alia would cover reliability, availability, utilisation and efficiency.

If you have any suggestions and any specific Comments please write to us.

Contact person : Director (Elect.)

Postal Address : Indian Railways
Centre for Advanced
Maintenance technology,
Maharajpur, Gwalior.
Pin code – 474 005

Phone : 0751 – 2470740
0751 – 2470803

Fax : 0751 – 2470841

Email : direlcamtech@gmail.com